

Čerpadlo ZQB

ZQB Pump

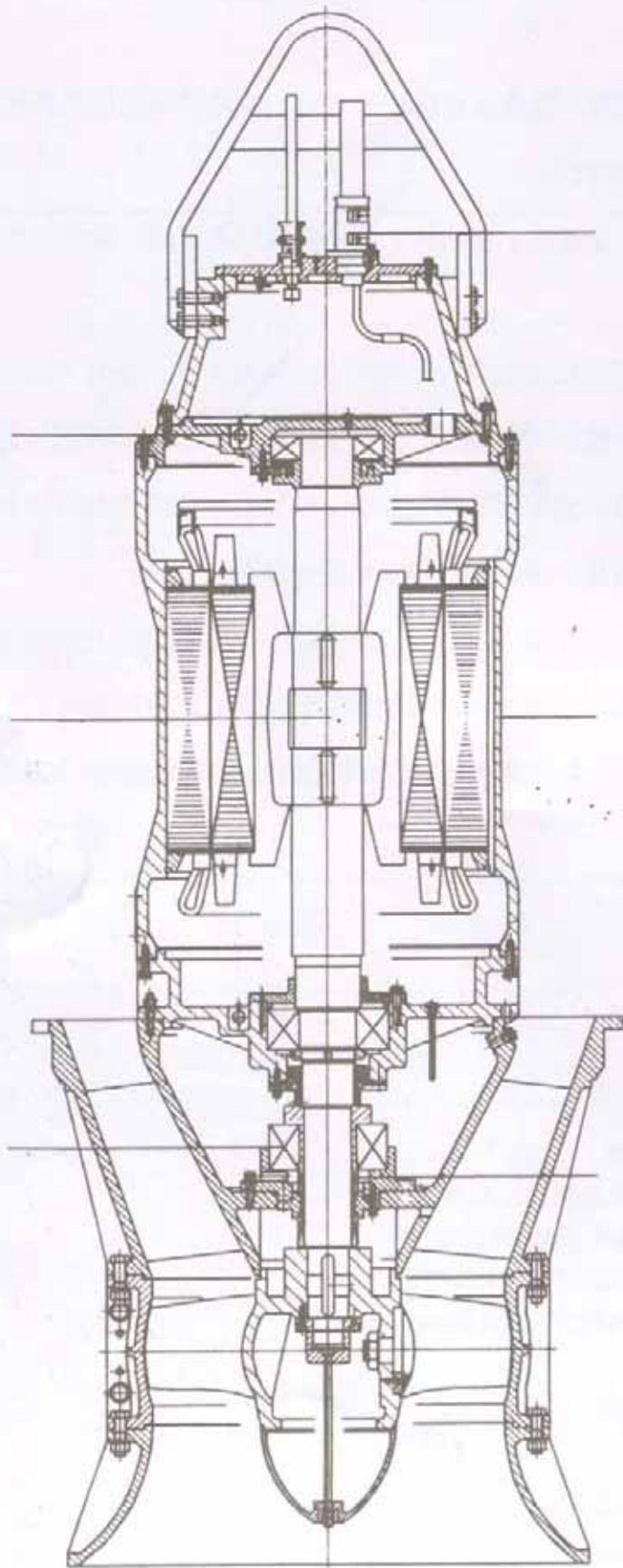



350ZQB-70

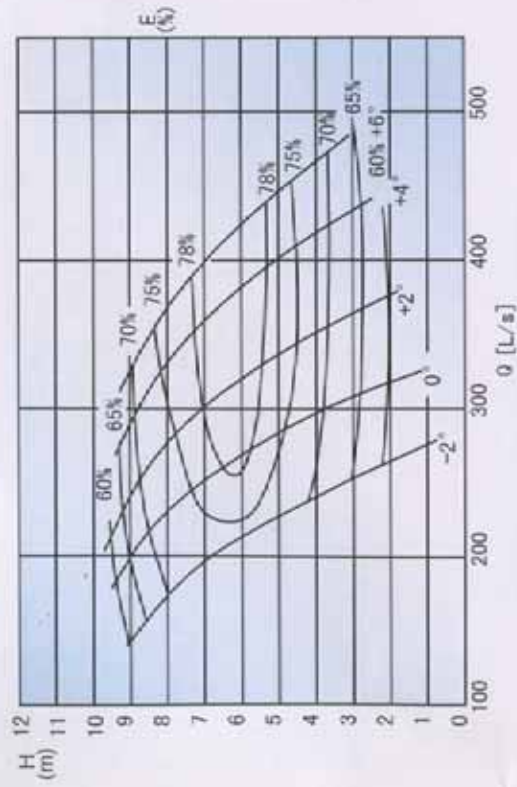

350ZQB-70D

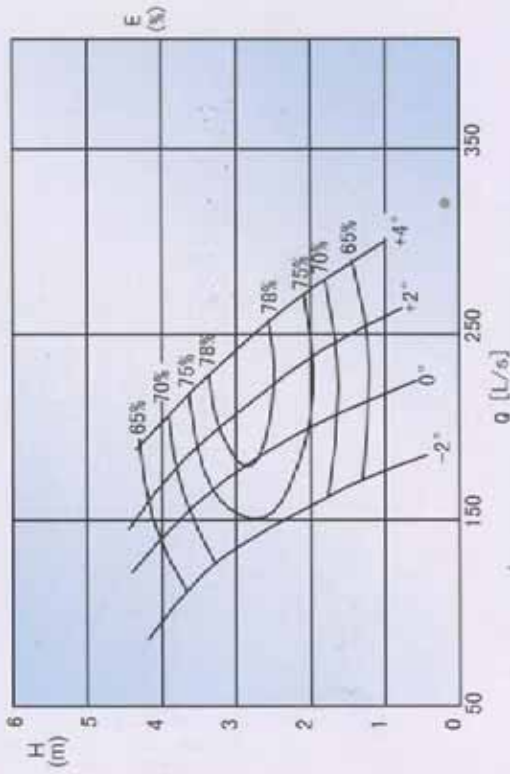

350ZQB-70D

Blade angle	Flow Q		Head H		Speed n r/min	Eff. η%	Power (kW)		Impeller Dia. mm
	m ³ /h	L/s	m	m					
-2°	673	187	7.45		1450	69.5		19.7	300
	828	230	4.77				22		
	900	250	3.42						
0°	763	212	8.67		1450	71		25.4	300
	957	266	6.21				30		
	1090	303	3.59						
+2°	972	270	8.3		1450	75.7		29.0	300
	1115	310	6.36				30		
	1250	347	4.52						
+4°	1170	325	7.8		1450	75.5		32.9	300
	1314	365	6.3				40		
	1440	400	4.71						
+6°	1314	365	8.1		1450	74.7		38.8	300
	1430	397	6.94				40		
	1540	428	5.8						

Blade angle	Flow Q		Head H		Speed n r/min	Eff. η%	Power (kW)		Impeller Dia. mm
	m ³ /h	L/s	m	m					
-2°	450	125	3.36		980	67		6.1	300
	554	154	2.16				7.5		
	602	167	1.54						
0°	515	143	3.94		980	68.9		8.0	300
	648	180	2.84				11		
	784	218	1.64						
+2°	655	182	3.79		980	73.8		9.2	300
	756	210	2.9				15		
	846	235	2.06						
+4°	789	219	3.52		980	78.5		9.6	300
	882	245	2.84				15		
	905	251	2.22						

350ZQB-100

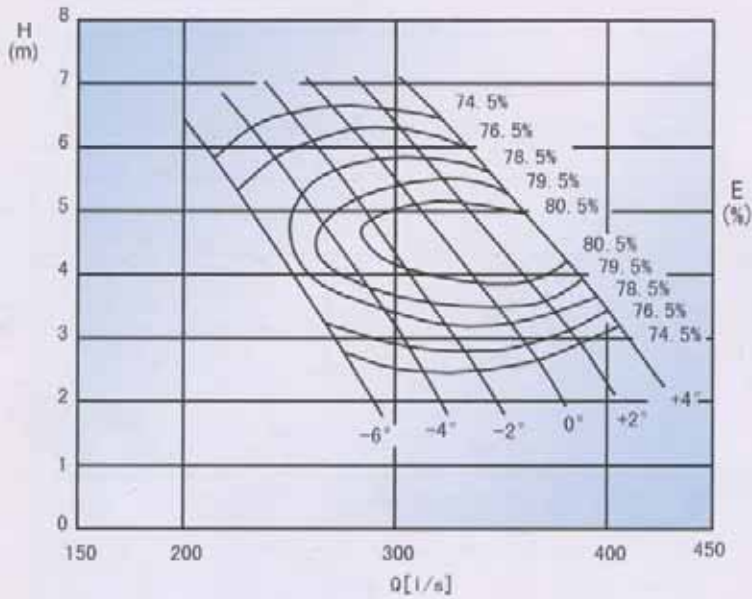

350ZQB-125

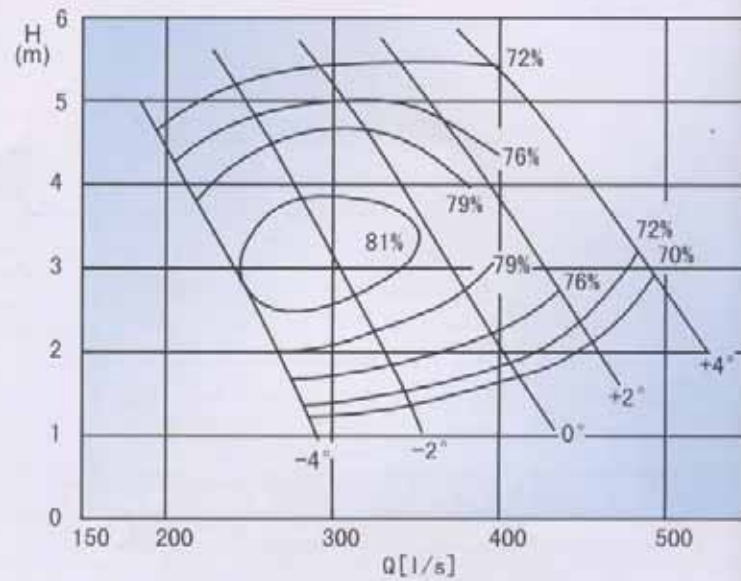

350ZQB-100

Blade angle	Flow Q		Head H	Speed n	Eff. η	Power (kW)		Impeller Dia. mm
	m ³ /h	L/s	m					
-6°	810	225	5.4	1450	76.5	15.6	22	300
	900	250	4.03		78.4	12.6		
	972	270	3.2		76.5	11.1		
-4°	878	244	5.8		76.5	18.1		
	1008	280	4.1		79.6	14.1		
	1080	300	3.2		76.5	12.3		
-2°	954	265	5.83		77.5	19.6		
	1080	300	4.2		80.2	15.4		
	1188	330	2.9		77.5	12.1		
0°	1033	287	6.0		77.5	21.8		
	1188	330	4.21		80.5	16.9		
	1285	357	2.89		77.5	13.1		
+2°	1091	303	6.0	76.7	23.3	30		
	1260	350	4.43	81	18.8			
	1368	380	3.2	76.5	15.6			
+4°	1170	325	6.4	75.5	27.0			
	1350	375	4.45	80.7	20.3			
	1440	400	3.4	76.5	17.4			

350ZQB-125

Blade angle	Flow Q		Head H	Speed n	Eff. η	Power (kW)		Impeller Dia. mm
	m ³ /h	L/s	m					
-4°	791	220	3.78	1450	79.1	10.3	18.5	300
	896	249	2.72		81.1	8.2		
	1005	279	1.39		70.2	5.4		
-2°	923	256	4.66		78	15.0		
	1113	309	2.84		81.7	10.5		
	1262	351	1.18		65.3	6.2		
0°	1111	309	5.02		75.6	20.1	22	
	1304	362	3.35		80.1	14.9		
	1534	426	1.22		64.6	7.9		
+2°	1163	323	5.89		70	26.7	37	
	1453	404	3.8		78.6	19.1		
	1649	458	2.05		70.3	13.1		
+4°	1422	395	5.47	69.4	30.5			
	1651	459	3.91	72.9	24.1			
	1782	495	2.84	70.9	19.5			

500ZQB-50

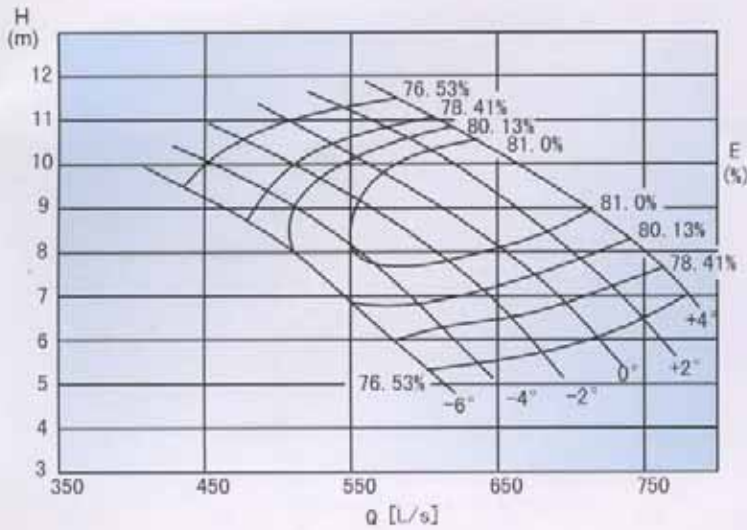

500ZQB-50D

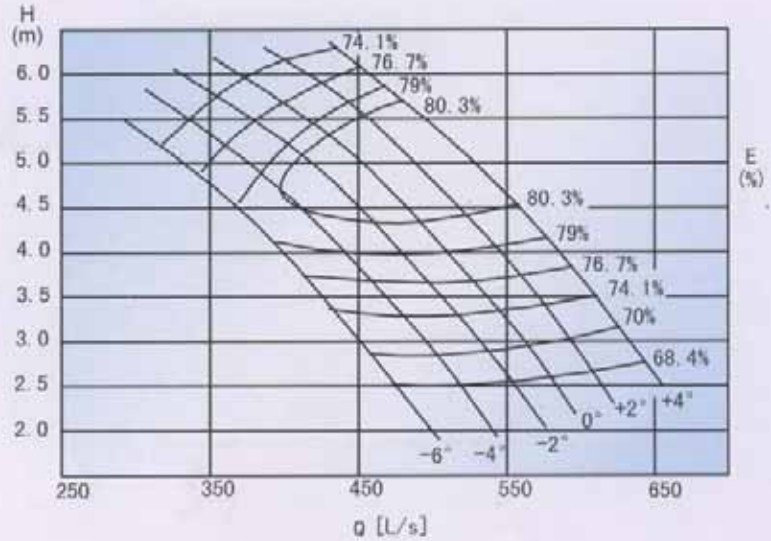

500ZQB-50

Blade angle	Flow Q		Head H m	Speed n r/min	Eff. η%	Power (kW)		Impeller Dia. mm
	m³/h	L/s						
-6°	1522	423	9.78	980	75.6	53.7	75	450
	1843	512	8.0		80.2	50.1		
	1981	550	6.85		78.3	47.2		
-4°	1600	444	10.12		75.6	58.4		
	1987	552	8.25		81	55.1		
	2183	606	6.65		78.3	50.5		
-2°	1698	472	10.48		75.6	64.1		
	2131	592	8.5		81	60.9		
	2368	658	6.61		78.3	54.5		
0°	1801	500	10.82		75.6	70.2		
	2300	639	8.54		81	66.1		
	2536	704	6.67		78.3	58.9		
+2°	2212	614	10.02	81	74.6			
	2430	675	8.7	81.5	70.7			
	2683	745	6.8	78.3	63.5			
+4°	2170	603	11.06	75.6	86.5			
	2556	710	9.0	81.5	76.9			
	2826	785	7.04	78.3	69.2			

500ZQB-50D

Blade angle	Flow Q		Head H m	Speed n r/min	Eff. η%	Power (kW)		Impeller Dia. mm
	m³/h	L/s						
-6°	1134	315	5.43	730	74.7	22.5	30	450
	1373	381	4.44		79.4	20.9		
	1476	410	3.8		77.5	19.7		
-4°	1192	331	5.62		74.7	24.4		
	1480	411	4.58		80.3	23.0		
	1626	452	3.69		77.5	21.1		
-2°	1265	351	5.82		74.7	26.9		
	1588	441	4.72		80.3	25.4		
	1764	490	3.68		77.5	22.8		
0°	1342	373	6.0		74.7	29.4		
	1713	476	4.74		80.3	27.6		
	1889	525	3.7		77.5	24.6		
+2°	1648	458	5.56	80.3	31.1			
	1810	503	4.83	80.7	29.5			
	1999	555	3.77	77.5	26.5			
+4°	1617	449	6.14	74.7	36.2			
	1904	529	4.99	80.7	32.1			
	2105	585	3.9	77.5	28.9			

500ZQB-70

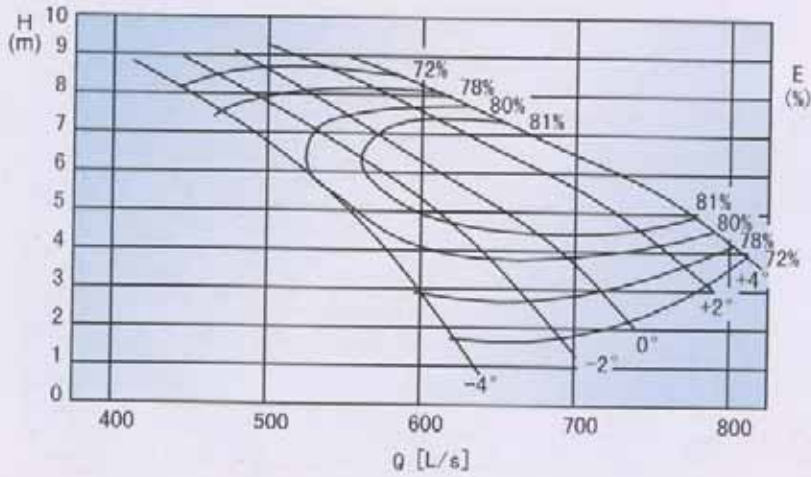

500ZQB-70D

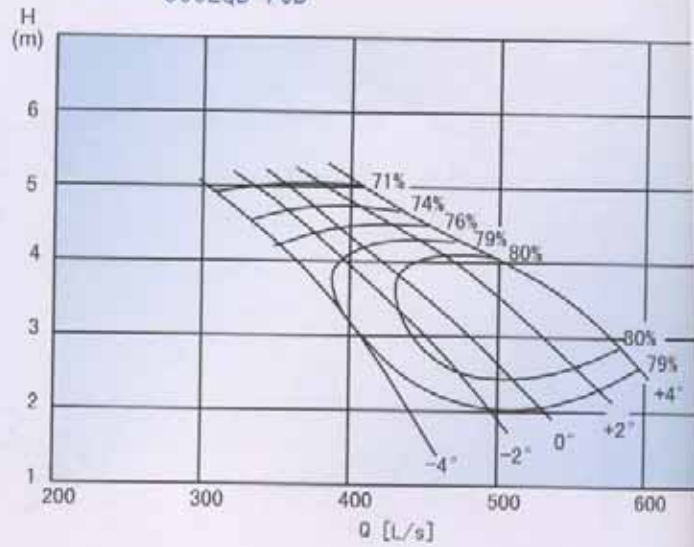

500ZQB-70

Blade angle	Flow Q		Head H	Speed n	Eff.		Power (kW)		Impeller Dia. mm
	m ³ /h	L/s	m	r/min	η%				
-4°	1370	381	9.44	980	70	50.3	55	450	
	1760	489	7.0		79.6	42.2			
	2050	569	4.35		78.5	31.0			
-2°	1720	478	8.2		74.5	51.6			
	2010	558	6.43		80	44.0			
	2250	625	4.9		73.5	40.9			
0°	2099	583	7.0		79.9	50.1			
	2160	600	6.3		81.2	45.7			
	2510	697	3.9		77	34.6			
+2°	2340	650	6.6		81.5	51.6			
	2560	711	5.6		82	47.6			
	2660	739	4.67		81.5	41.5			
+4°	2556	710	6.2	82.2	52.5				
	2700	750	5.6	83	49.6				
	2858	794	4.4	79	43.4				

500ZQB-70D

Blade angle	Flow Q		Head H	Speed n	Eff.		Power (kW)		Impeller Dia. mm
	m ³ /h	L/s	m	r/min	η%				
-4°	1020	283	5.32	730	68.2	21.7	30	450	
	1310	364	3.95		78.4	18.0			
	1530	425	2.45		77.2	13.2			
-2°	1170	325	5.16		73	22.5			
	1500	417	3.62		78.8	18.8			
	1675	465	2.76		71.9	17.5			
0°	1480	411	4.16		77.8	21.6			
	1610	447	3.56		80.1	19.5			
	1870	519	2.16		75.6	14.6			
+2°	1710	475	3.95		80.4	22.9			
	1910	531	3.1		80.9	19.9			
	1990	553	2.63		80.4	17.7			
+4°	1640	456	4.44	75.4	26.3				
	1860	517	3.52	82	21.8				
	2100	583	2.82	81.5	19.8				

500ZQB-100

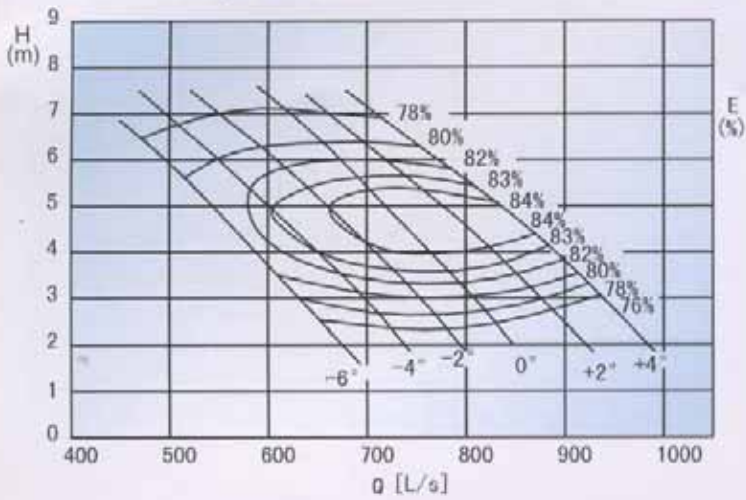

500ZQB-125

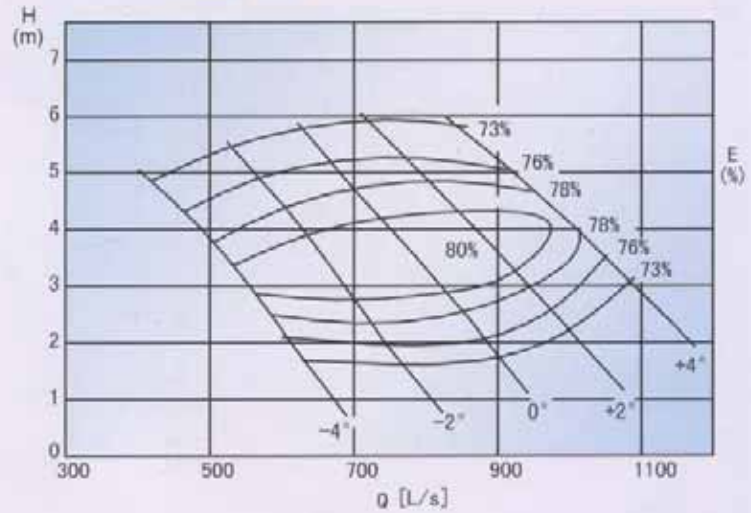

500ZQB-100

Blade angle	Flow Q		Head H	Speed n r/min	Eff. η%	Power (kW)		Impeller Dia. mm	
	m ³ /h	L/s	m						
-6°	1764	490	6.05	980	79.7	36.5	55	450	
	2160	600	3.7		82.0	26.6			
	2275	632	2.9		79.7	22.6			
-4°	1980	550	6.0		81.6	39.7			55
	2340	650	4.0		84.3	30.3			
	2466	685	3.15		81.6	25.9			
-2°	2160	600	6.18		81.6	44.6	55		
	2513	698	4.2		85.2	33.8			
	2700	750	3.1		81.6	28.0			
0°	2322	645	6.4		81.6	49.6			65
	2700	750	4.3		85.2	37.1			
	2916	810	3.05		81.6	29.7			
+2°	2498	694	6.4	81.6	53.4	65			
	2844	790	4.68	85.2	42.6				
	3114	865	3.25	81.6	33.8				
+4°	2736	760	6.2	81.6	56.6		65		
	2995	832	5.0	85.2	47.9				
	3276	910	3.6	81.6	39.4				

500ZQB-125

Blade angle	Flow Q		Head H	Speed n r/min	Eff. η%	Power (kW)		Impeller Dia. mm
	m ³ /h	L/s	m					
-4°	1620	450	4.55	980	75.0	26.8	30	450
	1962	545	3.2		80.5	21.3		
	2196	610	2.0		75.0	16.0		
-2°	2070	575	4.75		78.0	34.4	37	
	2394	665	3.3		81.5	26.4		
	2700	750	1.9		75.0	18.6		
0°	2484	690	4.8		78.5	41.4	45	
	2844	790	3.5		82.5	32.9		
	3204	890	2.0		73.5	23.8		
+2°	2808	780	5.1		76.5	51.0	55	
	3240	900	3.6		82.0	38.8		
	3510	975	2.5		75.0	31.9		
+4°	3366	935	4.4	78.6	51.3	55		
	3636	1010	4.0	79.5	49.9			
	3834	1065	3.6	76.5	49.2			

500HQB-50

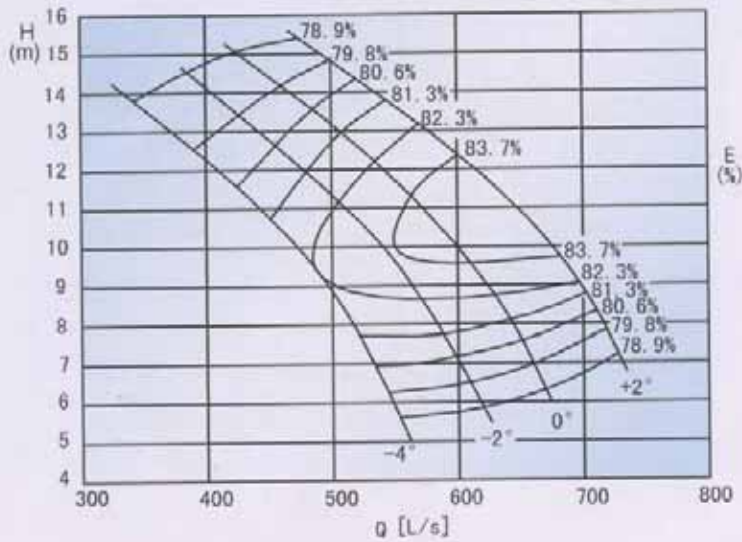

500HQB-50A

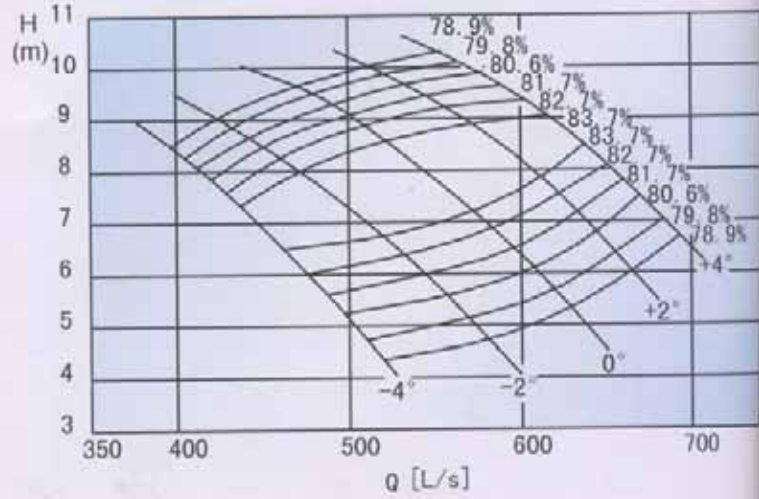

500HQB-50

Blade angle	Flow Q		Head H	Speed n r/min	Eff. η%	Power (kW)		Impeller Dia. mm
	m ³ /h	L/s	m					
-4°	1620	450	10.80	980	81.4	58.6	65	445
	1728	480	9.20		82.3	52.6		
	1861	517	8.00		81.4	49.8		
-2°	1735	482	11.70		81.4	68.0	75	
	1948	541	10.00		83.7	63.4		
	2102	584	8.00		81.4	56.3		
0°	1836	510	12.60		81.4	77.4	90	
	2157	599	10.00		84.0	70.0		
	2318	644	8.00		81.4	62.1		
+2°	2016	560	13.40		81.4	90.4	110	
	2340	650	11.00		84.0	83.5		
	2567	713	8.20		81.4	70.5		

500HQB-50A

Blade angle	Flow Q		Head H	Speed n r/min	Eff. η%	Power (kW)		Impeller Dia. mm
	m ³ /h	L/s	m					
-4°	1494	415	8.00	980	80.6	40.4	55	420
	1620	450	6.80		83.7	35.9		
	1800	500	5.20		80.6	31.6		
-2°	1620	450	8.50		81.7	45.9	75	
	1800	500	7.30		83.7	42.8		
	1958	544	6.00		81.7	39.2		
0°	1728	480	9.50		79.8	56.1	90	
	1980	550	8.00		83.7	51.6		
	2196	610	6.00		80.6	44.5		
+2°	1958	544	9.50		81.7	62.0	110	
	2160	600	8.20		83.7	57.7		
	2318	644	6.80		80.6	53.3		
+4°	2052	570	10.00	80.0	69.9	130		
	2268	630	8.70	83.7	64.2			
	2466	685	7.00	79.8	58.9			

500ZQB-160

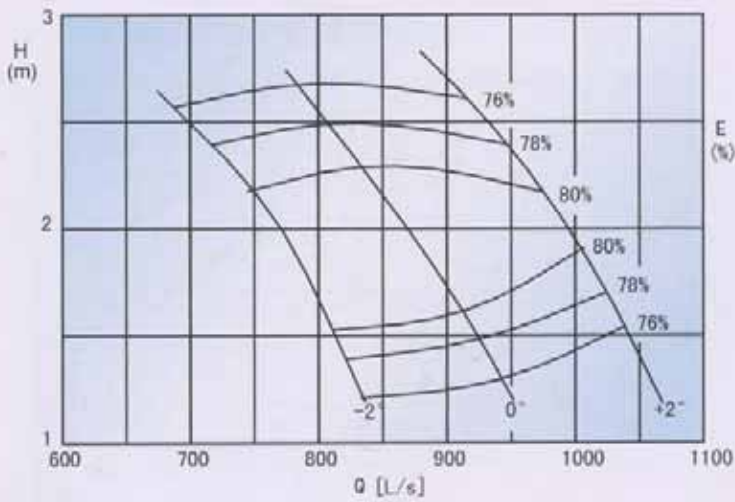

600ZQB-100

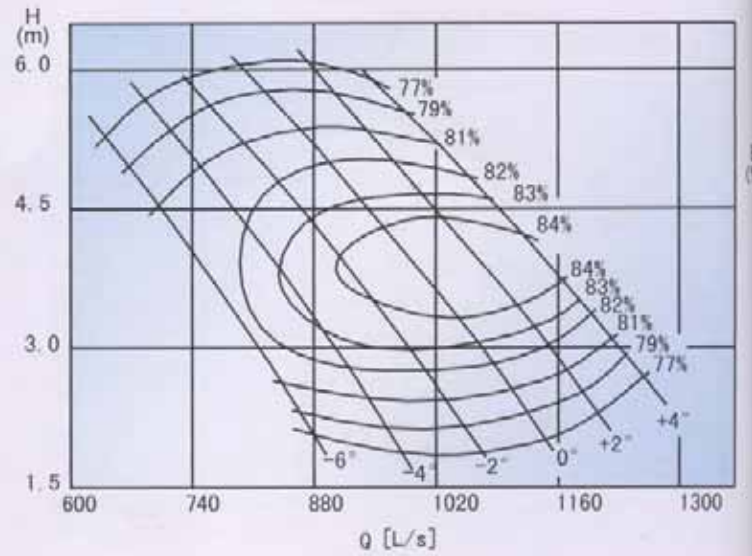

500ZQB-160

Blade angle	Flow Q		Head H	Speed n	Eff. η %	Power (kW)		Impeller Dia. mm
	m ³ /h	L/s	m	r/min				
-2°	2192	609	3.72	980	79.3	28.0	37	450
	2545	707	2.56		84.2	21.1		
	2804	779	1.71		79.3	16.5		
0°	2569	714	3.57		79.3	31.5		
	2956	821	2.57		84.2	24.6		
	3158	877	1.79		79.3	19.4		
+2°	2989	830	3.41		79.3	35.0	45	
	3194	887	3.02		82.0	32.1		
	3474	965	2.13		80.2	25.1		

600ZQB-100

Blade angle	Flow Q		Head H	Speed n	Eff. η %	Power (kW)		Impeller Dia. mm
	m ³ /h	L/s	m	r/min				
-6°	2556	710	4.45	730	81.1	38.2	45	550
	2808	780	3.49		81.6	32.7		
	3132	870	2.43		77.0	26.9		
-4°	3024	840	4.0		83.1	39.7		
	3132	870	3.54		83.4	36.2		
	3348	930	2.66		81.3	29.8		
-2°	3132	870	4.45		83.0	45.8		
	3420	950	3.49		84.0	38.7		
	3672	1020	2.52		81.2	31.1		
0°	3348	930	4.47		82.7	49.3		
	3672	1020	3.59		84.2	42.7		
	3852	1070	2.95		83.0	37.3		
+2°	3924	1090	3.73		84.0	47.5		
	4104	1140	3.37		84.2	44.8		
	4176	1160	2.90		81.7	40.4		
+4°	4176	1160	3.79		84.2	51.2		
	4284	1190	3.41		83.3	47.8		
	4482	1245	3.0		81.0	45.2		

600HQB-50

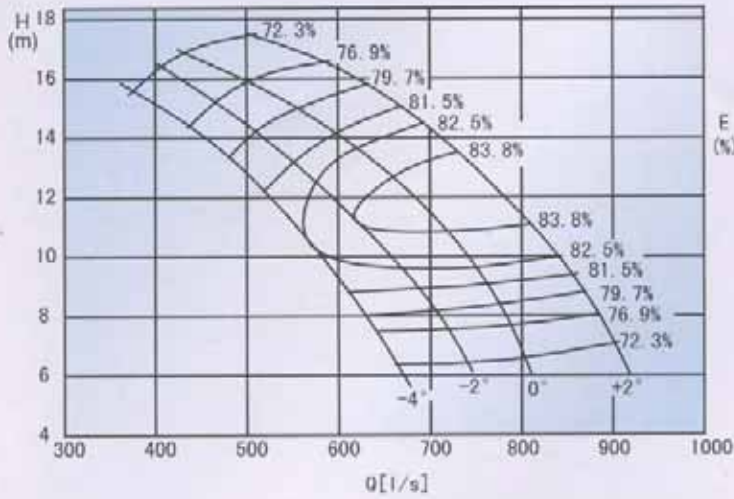

600HQB-50A

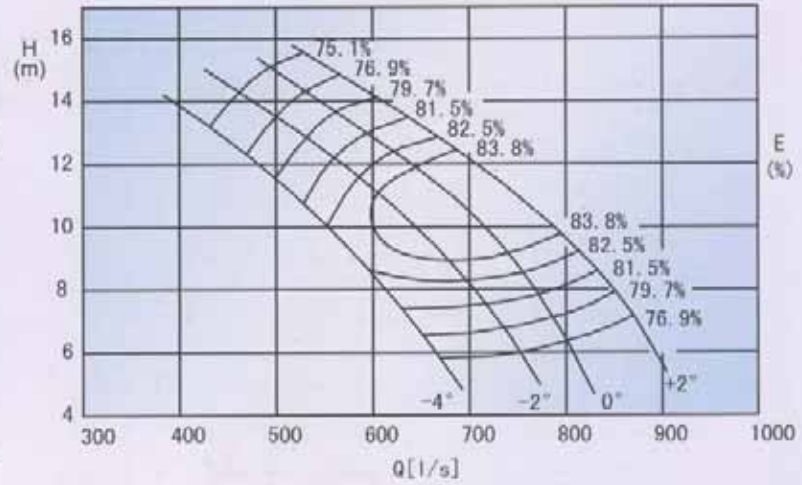

600HQB-50

Blade angle	Flow Q		Head H	Speed n	Eff. η%	Power (kW)		Impeller Dia. mm
	m ³ /h	L/s	m	r/min				
-4°	1602	445	14.30	980	77.0	81.1	95	471
	2088	580	10.20		82.5	70.3		
	2304	640	7.42		77.0	60.5		
-2°	1710	475	15.20		77.0	92.0	110	
	2322	645	11.00		83.0	83.9		
	2574	715	7.50		77.0	68.3		
0°	1847	513	15.90		77.0	103.9	132	
	2459	683	12.00		83.9	95.8		
	2844	790	7.65		77.0	77.0		
+2°	2052	570	16.80		77.0	122.0		
	2808	780	12.00		83.9	109.4		
	3186	885	7.90		77.0	89.1		

600HQB-50A

Blade angle	Flow Q		Head H	Speed n	Eff. η%	Power (kW)		Impeller Dia. mm
	m ³ /h	L/s	m	r/min				
-4°	1602	445	12.90	980	77.0	73.1	95	471
	2106	585	9.00		82.5	62.6		
	2412	670	5.80		77.0	49.5		
-2°	1782	495	13.65		77.0	86.1	110	
	2322	645	10.00		83.9	75.4		
	2718	755	5.90		77.0	56.8		
0°	1926	535	14.20		77.0	96.8	132	
	2520	700	10.50		83.9	85.9		
	2952	820	6.25		77.0	65.3		
+2°	2070	575	14.70		77.0	107.7		
	2700	750	11.00		83.9	96.5		
	3118	866	6.70		77.0	73.9		

600ZQB-160

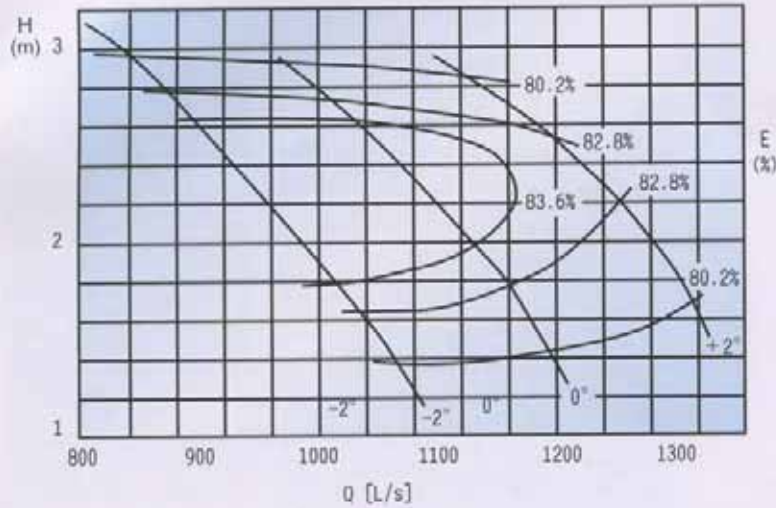

700ZQB-50

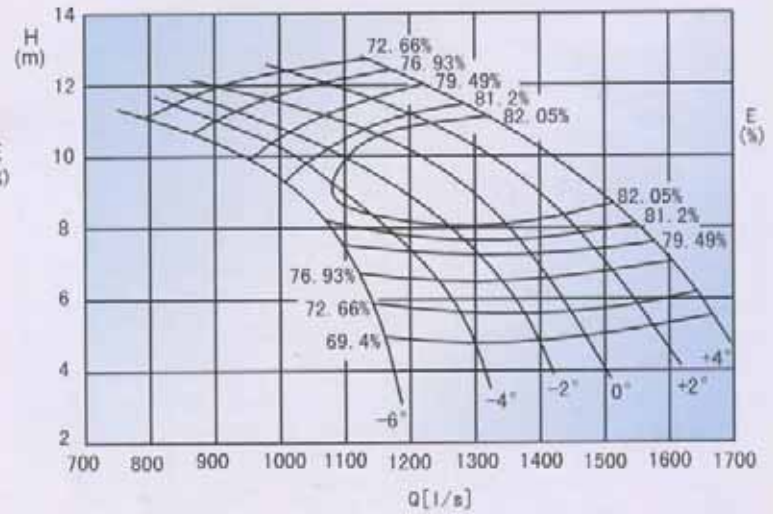

600ZQB-160

Blade angle	Flow Q		Head H	Speed n	Eff. η %	Power (kW)		Impeller Dia. mm
	m ³ /h	L/s	m	r/min				
-2°	2981	828	3.08	730	80.2	31.2	37	550
	3463	962	2.12		85.0	23.5		
	3814	1059	1.42		80.2	18.4		
0°	3493	970	2.96		80.2	35.1	45	
	4169	1158	1.77		82.8	24.3		
	4295	1193	1.48		80.2	21.6		
+2°	4065	1129	2.83		80.2	39.1	45	
	4345	1207	2.51		82.8	35.9		
	4728	1313	1.76		81.1	28.0		

700ZQB-50

Blade angle	Flow Q		Head H	Speed n	Eff. η %	Power (kW)		Impeller Dia. mm
	m ³ /h	L/s	m	r/min				
-6°	2827	785	11.07	730	72.7	117.4	132	600
	3715	1032	8.75		81.5	108.7		
	4135	1149	4.24		65.0	73.5		
-4°	3893	1081	9.39		82.0	121.5	160	
	4010	1114	9.00		82.1	119.8		
	4698	1305	5.60		72.7	98.6		
-2°	3103	862	11.70		72.7	136.1	160	
	4334	1204	9.00		82.5	128.8		
	5112	1420	5.25		70.0	104.5		
0°	3436	954	11.32		76.9	137.8	185	
	4653	1293	9.24		82.1	142.7		
	5191	1442	4.81		72.7	93.6		
+2°	3879	1078	12.05		76.9	165.6	185	
	4896	1360	9.50		83.0	152.7		
	5738	1594	5.85		72.7	126.8		
+4°	4749	1319	11.07		82.0	174.7	185	
	5162	1434	9.75		83.0	165.2		
	6017	1671	6.14		72.7	138.5		

700HQB-50

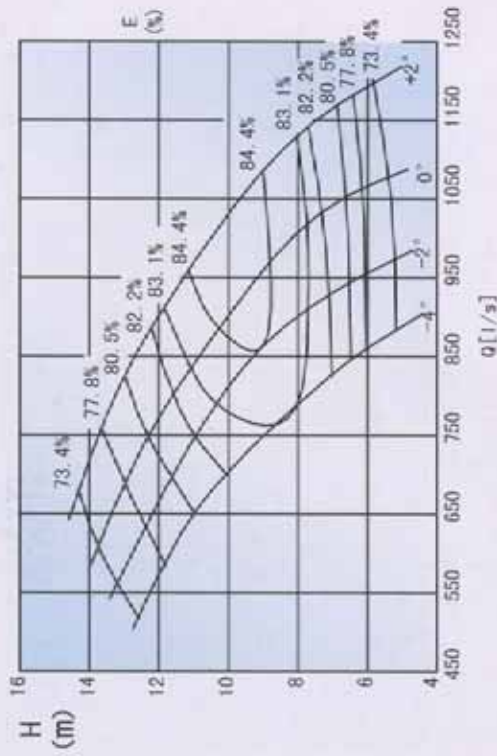

700HQB-50

Blade angle	Flow Q		Head H m	Speed n r/min	Eff. η %	Power (kW)	Impeller Dia. mm
	m ³ /h	L/s					
-4°	2340	650	11.00	730	80.0	87.7	571.5
	2844	790	8.00		83.0	74.7	
	3024	840	6.60		80.5	67.6	
-2°	2736	760	10.80	730	82.3	97.8	571.5
	3114	865	9.00		84.5	90.4	
	3395	943	6.50		80.0	75.2	
0°	2700	750	12.30	730	80.5	112.4	571.5
	3240	900	10.00		84.5	104.5	
	3701	1028	7.00		81.0	87.2	
+2°	2970	825	13.00	730	80.2	131.2	571.5
	3492	970	11.00		84.5	123.9	
	4122	1145	7.60		82.0	104.1	

900HQB-50

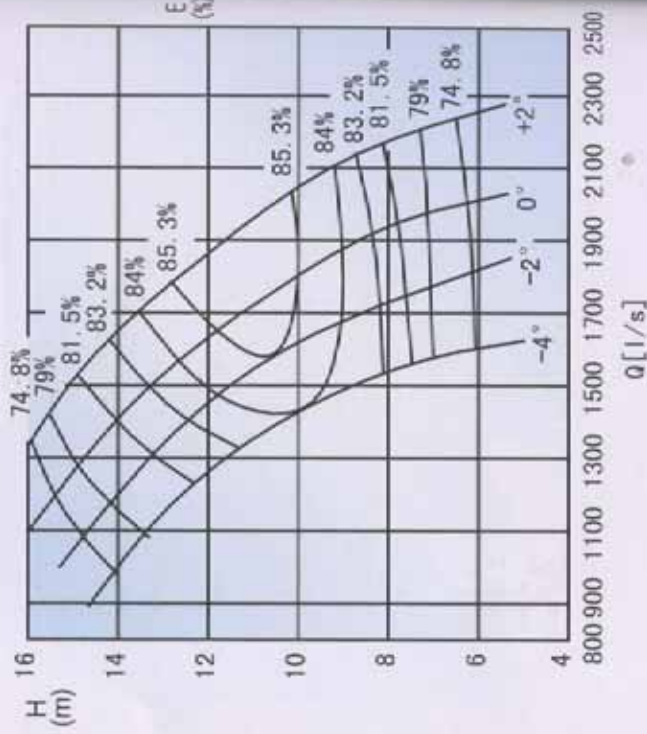

900HQB-50

Blade angle	Flow Q		Head H m	Speed n r/min	Eff. η %	Power (kW)	Impeller Dia. mm
	m ³ /h	L/s					
-4°	4068	1130	13.10	580	80.0	181.5	755
	5303	1473	9.20		84.2	157.9	
	5724	1590	6.80		80.0	132.6	
-2°	4828	1341	13.00	580	82.0	208.6	755
	5688	1580	10.50		84.8	191.9	
	6336	1760	7.40		81.0	157.7	
0°	5220	1450	13.70	580	82.7	236.6	755
	6495	1804	10.00		85.0	208.2	
	6948	1930	7.93		80.5	186.5	
+2°	5447	1513	15.00	580	80.7	275.9	755
	6732	1870	12.00		85.5	257.5	
	7632	2120	9.00		81.0	231.1	

700ZQB-50D

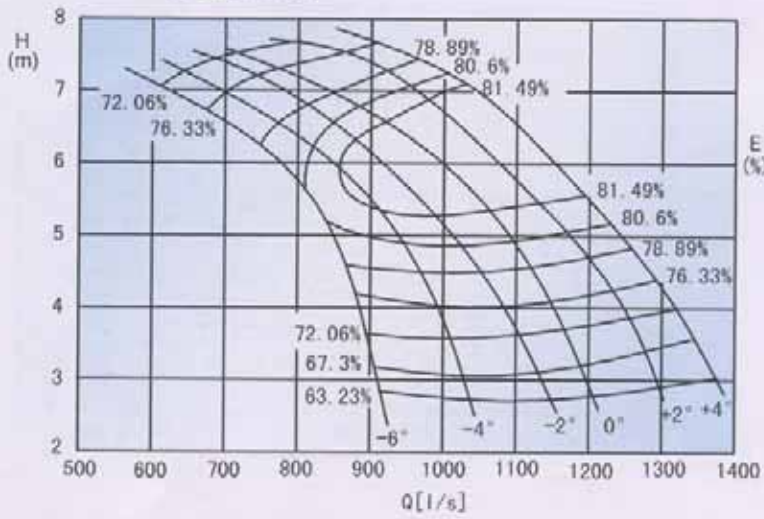

700ZQB-70

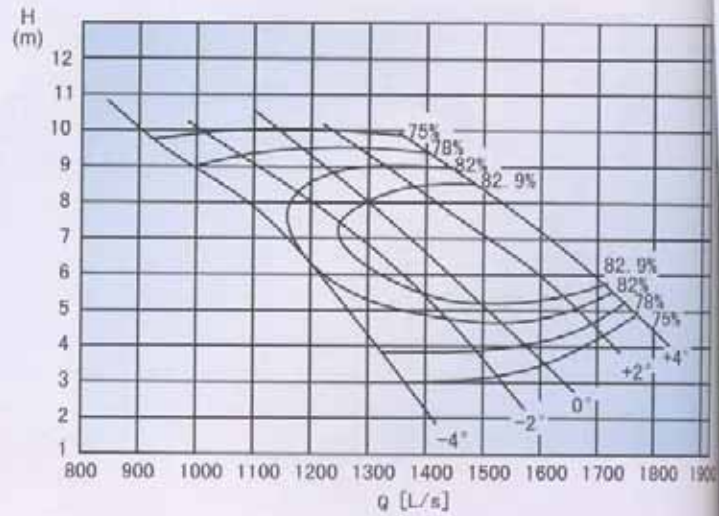

700ZQB-50D

Blade angle	Flow Q		Head H m	Speed n r/min	Eff. η%	Power (kW)		Impeller Dia. mm
	m ³ /h	L/s						
-6°	2246	624	6.99	590	71.9	59.5	75	600
	2952	820	5.52		80.9	54.9		
	3285	913	2.68		64.0	37.5		
-4°	3093	859	5.93		81.4	61.4		
	3186	885	5.68		81.8	60.3		
	3733	1037	3.54		71.9	50.1		
-2°	2465	685	7.39		71.9	69.0	90	
	3444	957	5.68		81.9	65.1		
	4062	1128	3.31		70.0	52.3		
0°	2730	758	7.15		76.2	69.8		
	3697	1027	5.83		81.5	72.1		
+2°	4124	1146	3.04		71.9	47.5		
	3082	856	7.61	76.2	83.9	110		
	3890	1081	6.00	82.4	77.2			
+4°	4559	1266	3.69	71.9	63.8			
	3773	1048	6.99	81.4	88.3			
	4102	1139	6.15	82.4	83.4			
	4781	1328	3.88	71.9	70.3			

700ZQB-70

Blade angle	Flow Q		Head H m	Speed n r/min	Eff. η%	Power (kW)		Impeller Dia. mm
	m ³ /h	L/s						
-4°	3038	844	10.80	730	72.1	124.0	160	650
	3908	1086	8.04		82.0	104.4		
	4563	1268	4.99		81.0	76.6		
-2°	3828	1063	9.41		76.5	128.3		
	4467	1241	7.58		81.4	113.4		
	4995	1388	5.63		75.4	101.6		
0°	4595	1276	8.04		81.3	123.8		
	4795	1332	7.25		82.5	114.8		
	5562	1545	4.48		78.6	86.1		
+2°	5195	1443	7.58		82.6	129.9		
	5682	1578	6.31		83.5	117.0		
+4°	5922	1645	5.36		82.8	104.5		
	5760	1600	7.20	83.2	135.8			
	5994	1665	6.43	84.2	124.7			
	6340	1761	5.05	80.3	108.7			

700ZQB-70D

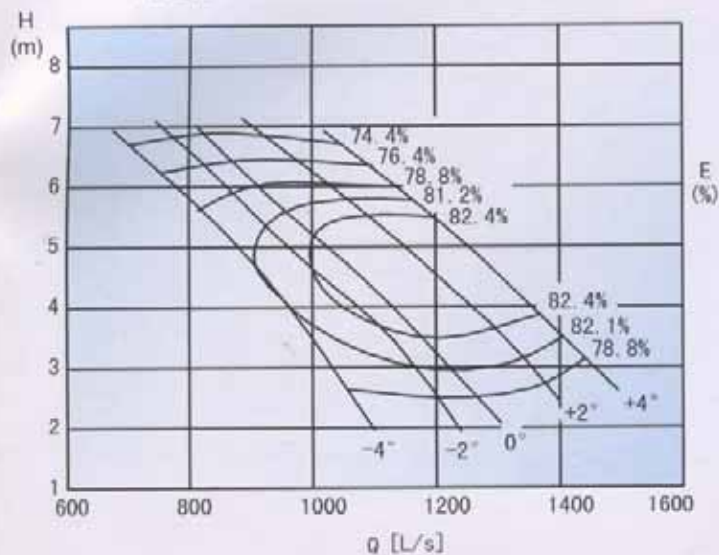

700ZQB-70*

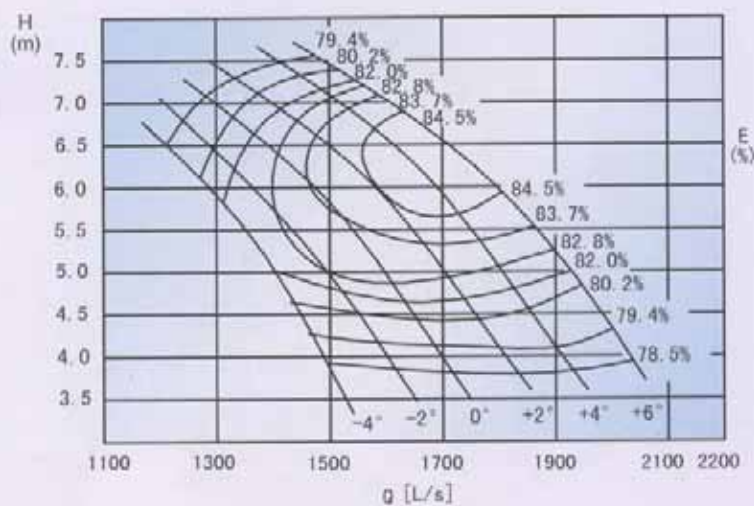

700ZQB-70D

Blade angle	Flow Q		Head H	Speed n	Eff. η	Power (kW)		Impeller Dia. mm
	m ³ /h	L/s	m	r/min				
-4°	2410	669	6.96	590	70.5	64.8	80	650
	3110	864	5.17		80.0	54.8		
	3660	1017	3.20		78.8	40.5		
-2°	3786	774	6.75		75.0	68.3		
	3567	988	4.74		80.5	57.1		
	3974	1104	3.61		75.9	51.5		
0°	3506	974	5.44		79.4	66.5		
	3820	1061	4.66		81.5	59.5		
	4446	1235	2.85		77.4	44.6		
+2°	4060	1128	5.17		81.8	69.9		
	4529	1258	4.00		82.3	60.0		
	4720	1311	3.44		81.8	54.1		
+4°	4658	1294	4.60	83.3	70.1			
	4976	1382	3.69	82.8	60.4			
	5120	1422	3.20	79.3	56.3			

700ZQB-70*

Blade angle	Flow Q		Head H	Speed n	Eff. η	Power (kW)		Impeller Dia. mm
	m ³ /h	L/s	m	r/min				
-4°	4356	1210	6.45	590	79.4	96.4	132	650
	4860	1350	5.5		82.0	88.8		
	5256	1460	4.25		79.4	76.7		
-2°	4572	1270	6.65		80.0	103.6		
	5184	1440	5.5		82.8	93.8		
	5688	1580	4.15		79.4	81.0		
0°	4824	1340	6.8		80.8	110.6		
	5436	1510	5.7		83.7	100.9		
	6084	1690	4.05		76.4	87.9		
+2°	5040	1400	7		81.1	118.5		
	5652	1570	6		84.0	110.0		
	6480	1800	4.1		79.4	91.2		
+4°	5256	1460	7.25	81.1	128.0			
	6012	1670	6.2	84.5	120.2			
	6840	1900	4.17	79.4	97.9			
+6°	5544	1540	7.45	81.1	138.8			
	6228	1730	6.45	84.5	129.5			
	7200	2000	4.47	79.4	110.5			

700ZQB-100

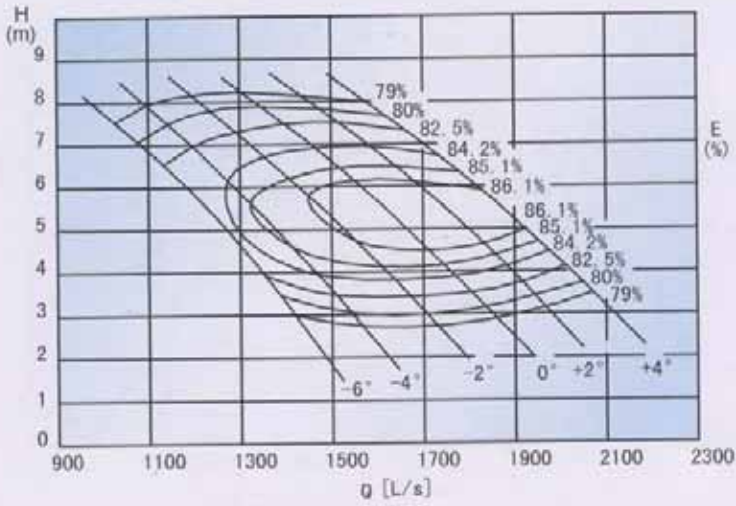

700ZQB-100D

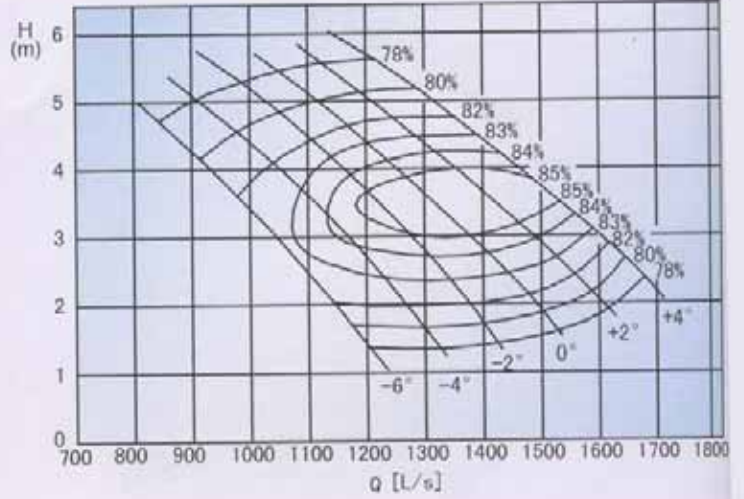

700ZQB-100

Blade angle	Flow Q		Head H	Speed n	Eff. η	Power (kW)		Impeller Dia. mm
	m ³ /h	L/s	m	r/min				
-6°	3898	1080	7.00	730	79.0	93.9	110	650
	4572	1270	5.00		81.0	76.9		
	5040	1400	3.30		79.0	57.4		
-4°	4176	1160	7.20		79.0	103.7	132	
	4860	1350	5.30		82.5	85.1		
	5472	1520	3.00		79.0	56.6		
-2°	4572	1270	7.50		79.0	118.3	160	
	5329	1480	5.50		83.0	96.2		
	5976	1660	3.36		79.0	69.1		
0°	4968	1380	7.60		79.0	130.2	185	
	5850	1625	5.50		83.4	105.1		
	6516	1810	3.45		79.0	77.5		
+2°	5400	1500	7.65		79.0	142.5	110	
	6300	1750	5.60		83.4	113.2		
	6948	1930	3.55		79.0	85.1		
+4°	5760	1600	7.60		79.0	151.0	110	
	6680	1850	5.70		83.4	124.0		
	7380	2050	3.70		79.0	94.2		

700ZQB-100D

Blade angle	Flow Q		Head H	Speed n	Eff. η	Power (kW)		Impeller Dia. mm
	m ³ /h	L/s	m	r/min				
-6°	3021	839	4.76	590	78.0	50.2	55	650
	3693	1026	3.20		82.0	39.3		
	4166	1157	1.89		78.0	27.5		
-4°	3230	897	5.13		80.0	56.4	75	
	4172	1159	3.14		84.0	42.5		
	4345	1207	1.98		78.0	30.1		
-2°	3368	936	5.60		78.0	65.9	90	
	4506	1252	3.17		85.0	45.8		
	4979	1383	1.94		80.0	32.9		
0°	3981	1106	5.09		80.0	69.0	110	
	4875	1354	3.20		85.0	50.0		
	5363	1490	2.02		80.0	36.9		
+2°	4173	1159	5.34		78.0	77.9	110	
	5171	1436	3.40		85.0	56.4		
	5769	1603	2.03		78.0	40.9		
+4°	4196	1166	5.88		78.0	86.2	110	
	5540	1539	3.40		85.0	60.4		
	6079	1689	2.29		78.0	48.6		

700ZQB-125

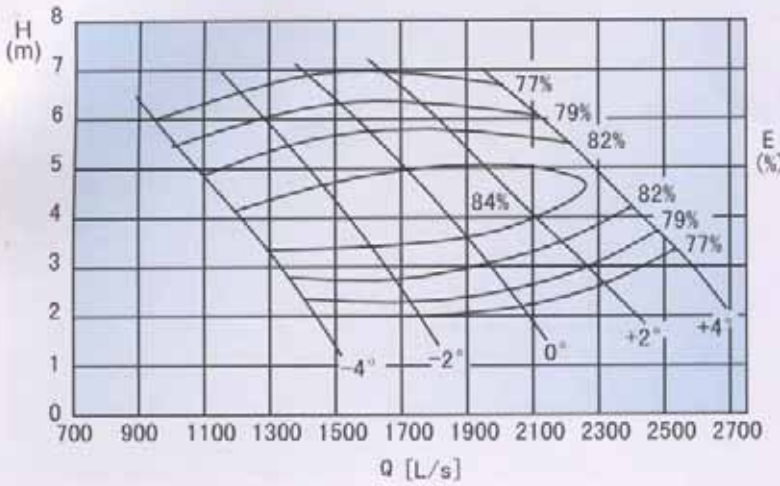

700ZQB-125D

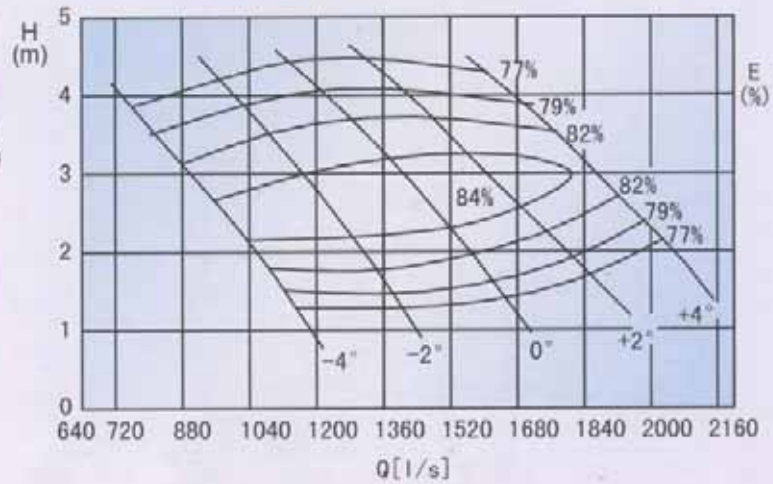

700ZQB-125

Blade angle	Flow Q		Head H	Speed n	Eff. η%	Power (kW)		Impeller Dia. mm
	m ³ /h	L/s	m	r/min				
-4°	3398	944	6.10	730	77.0	73.4	90	650
	4572	1270	3.61		84.0	53.5		
	5141	1428	2.12		78.0	38.1		
-2°	4799	1333	5.80		79.0	96.0	110	
	5533	1537	4.05		82.5	74.0		
	6048	1680	2.57		79.0	53.8		
0°	5825	1618	5.67		81.0	111.1	132	
	6635	1843	4.05		82.5	88.8		
	7222	2006	2.70		79.0	67.3		
+2°	6487	1802	6.08		79.0	136.0	160	
	7441	2067	4.32		82.5	106.2		
	7956	2210	3.24		79.0	88.9		
+4°	8352	2320	4.81	83.0	131.9	160		
	8402	2334	4.17	82.0	116.4			
	8910	2475	3.73	79.0	114.6			

700ZQB-125D

Blade angle	Flow Q		Head H	Speed n	Eff. η%	Power (kW)		Impeller Dia. mm
	m ³ /h	L/s	m	r/min				
-4°	2725	757	3.92	590	76.0	38.3	45	650
	3668	1019	2.32		83.3	27.8		
	4104	1140	1.36		77.2	19.7		
-2°	3636	1010	3.98		78.5	50.2	55	
	4511	1253	2.40		83.8	35.2		
	5051	1403	1.24		75.5	22.6		
0°	4392	1220	4.00		79.5	60.2	75	
	5314	1476	2.57		83.8	44.4		
	5922	1645	1.51		76.5	31.9		
+2°	5069	1408	4.04		79.0	70.6	90	
	5951	1653	2.74		83.3	53.3		
	6400	1778	2.02		80.0	44.0		
+4°	5995	1665	4.00	78.8	82.9	90		
	6682	1856	3.10	82.5	68.4			
	6732	1870	3.03	82.5	67.4			

700ZQB-160

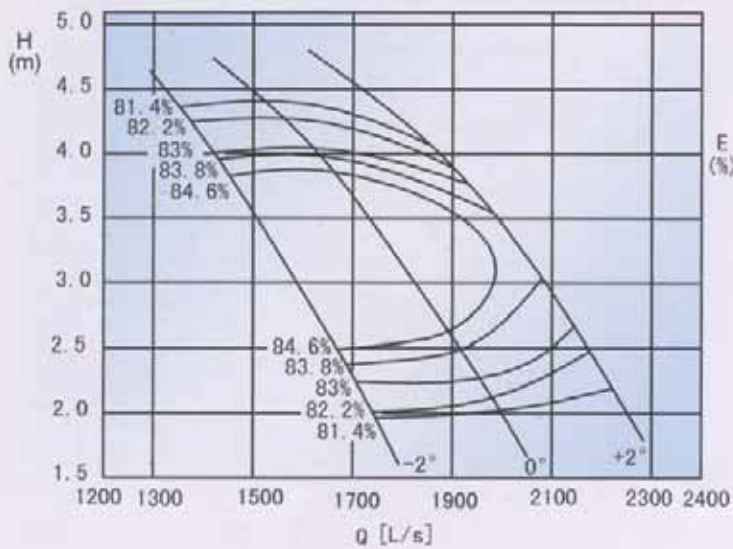

900ZQB-50

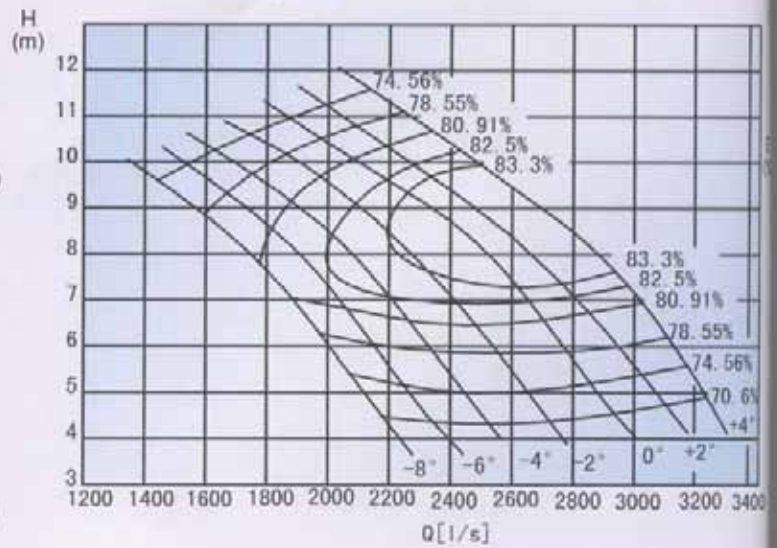

700ZQB-160

Blade angle	Flow Q		Head H m	Speed n r/min	Eff. η %	Power (kW)		Impeller Dia. mm
	m ³ /h	L/s						
-2°	4922	1367	4.30	730	81.4	70.9	90	650
	5715	1588	2.96		85.0	51.2		
	6295	1749	1.98		81.4	41.7		
0°	5766	1602	4.13		81.4	79.7		
	6637	1844	2.97		85.6	62.8		
	7086	1968	2.07		81.4	49.1		
+2°	6710	1864	3.95		81.4	88.7	110	
	7171	1992	3.50		83.8	81.6		
	7798	2166	2.46		82.2	63.6		

900ZQB-50

Blade angle	Flow Q		Head H m	Speed n r/min	Eff. η %	Power (kW)		Impeller Dia. mm
	m ³ /h	L/s						
	5161	1434	9.65	490	74.6	181.9	220	850
	6472	1798	7.82		81.0	170.3		
	7596	2110	4.58		70.6	134.3		
-6°	5659	1572	9.77		75.0	200.9		
	7139	1983	7.82		82.8	183.7		
	8578	2383	3.83		66.6	134.4		
-4°	5638	1566	10.31		74.6	212.3		
	7761	2156	8.06		84.0	202.9		
	9187	2552	4.37		70.6	155.0		
-2°	6558	1822	10.24		78.5	233.1	250	
	7995	2221	8.3		84.0	215.3		
	10038	2788	3.91		67.0	159.6		
0°	7457	2071	10.19		80.9	256.0	280	
	8882	2467	8.34		84.2	239.7		
	10570	2936	4.42		70.6	180.3		
+2°	7402	2056	10.9	78.5	280.1	315		
	9350	2597	8.55	84.0	259.3			
	11357	3155	4.02	66.6	186.6			
+4°	7859	2183	11.2	78.5	305.5	355		
	9830	2731	8.79	84.0	280.3			
	11774	3271	4.88	70.6	221.8			

900ZQB-70

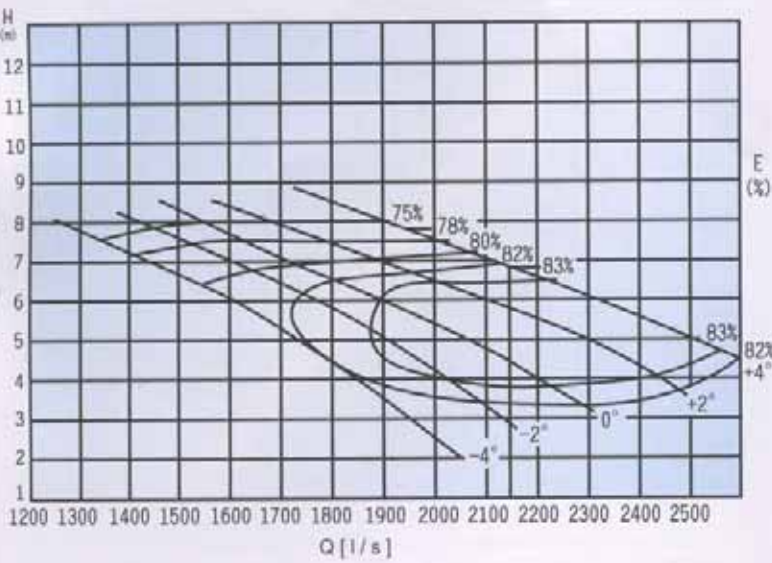

900ZQB-70*

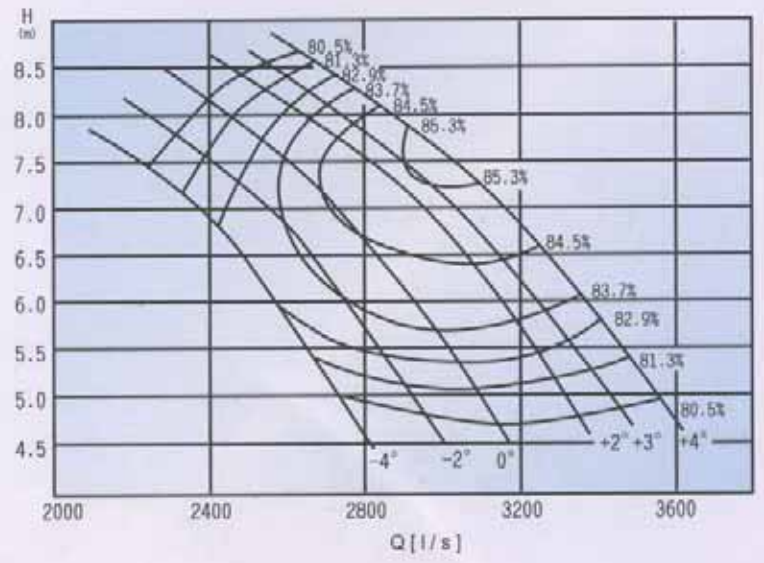

900ZQB-70

Blade angle	Flow Q		Head H	Speed n	Eff. η%	Power (kW)		Impeller Dia. mm	
	m³/h	L/s	m	r/min					
-4°	4500	1250	8.06	490	74.0	133.6	160	850	
	5800	1611	5.98		82.3	114.8			
	6770	1881	3.72		81.4	84.3			
-2°	5190	1442	7.82		77.5	142.7			250
	6620	1839	5.49		82.7	119.8			
	7410	2058	4.19		77.0	109.9			
0°	6510	1808	6.41		81.8	139.0			280
	7200	2000	5.40		83.6	126.7			
	8250	2292	3.33		80.1	93.5			
+2°	7560	2100	6.05		84.0	146.9			315
	8420	2339	4.70		84.4	127.8			
	8790	2442	4.00		84.0	114.1			
+4°	7740	2150	6.82	84.2	170.1	350			
	8650	2403	5.60	85.3	154.7				
	9300	2583	4.27	84.8	127.6				

900ZQB-70* 开

Blade angle	Flow Q		Head H	Speed n	Eff. η%	Power (kW)		Impeller Dia. mm
	m³/h	L/s	m	r/min				
-4°	8748	2430	6.80	490	83.0	195.3	220	850
	9288	2580	6.00		83.0	183.0		
	9839	2733	5.00		80.5	166.5		
-2°	8350	2319	7.73		80.5	218.5	250	
	9648	2680	6.50		83.8	203.9		
	10620	2950	4.87		80.5	175.1		
0°	8640	2400	8.17		80.5	238.9	280	
	10080	2800	6.70		84.5	217.8		
	11268	3130	4.77		80.5	181.9		
+2°	8964	2490	8.40		80.5	254.9	315	
	10656	2960	7.00		84.5	240.5		
	11988	3330	4.77		80.5	193.6		
+3°	9576	2660	8.25	82.9	259.6	350		
	11340	3150	6.52	84.5	238.4			
	12420	3450	4.82	80.5	202.6			
+4°	9720	2700	8.50	82.1	274.2	380		
	11124	3090	7.33	85.3	260.5			
	12816	3560	4.93	80.5	213.9			

900ZQB-100

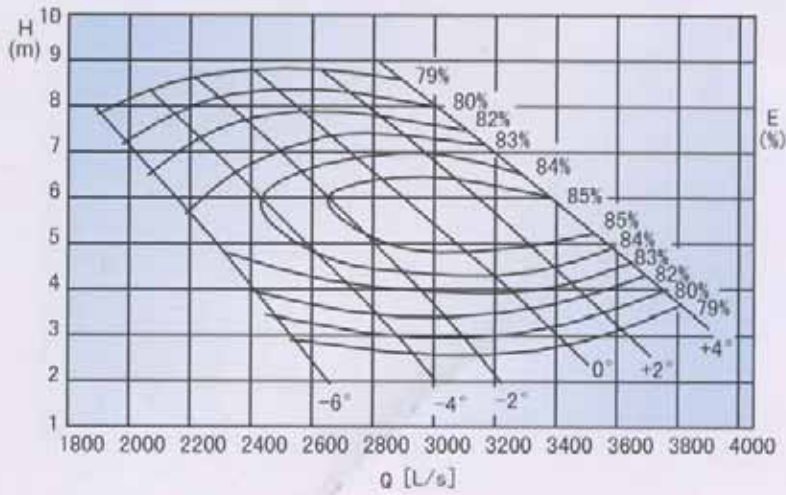

900ZQB-100D

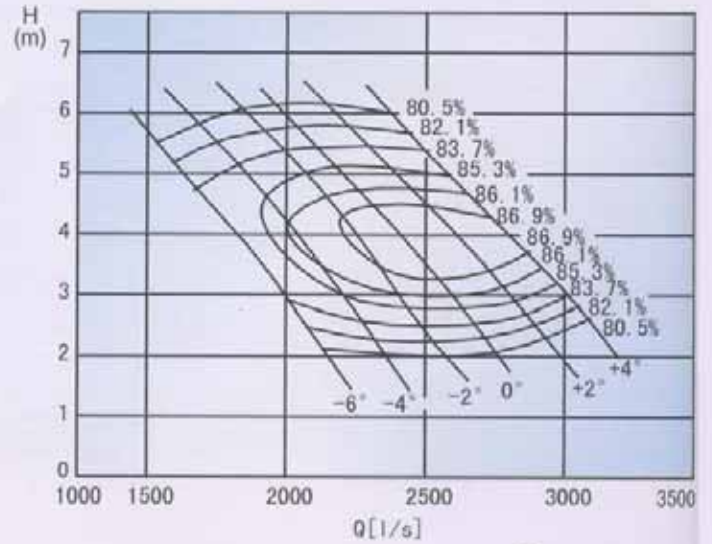

900ZQB-100

Blade angle	Flow Q		Head H	Speed n	Eff. η	Power (kW)		Impeller Dia. mm
	m ³ /h	L/s	m	r/min				
-6°	7416	2060	6.75	590	81.5	167.4	220	850
	8316	2310	5.50		84.0	148.4		
	8856	2460	4.00		82.0	117.7		
-4°	8208	2280	7.00		83.0	188.6		
	9306	2585	5.50		84.5	165.1		
	9792	2720	4.00		81.5	131.0		
-2°	8686	2413	7.50		82.5	215.2	250	
	9756	2710	5.75		85.0	179.8		
	10650	2968	4.00		82.0	141.6		
0°	9720	2700	7.25		83.5	230.0		
	10728	2980	5.50		85.0	189.2		
	11448	3180	4.50		83.5	168.1		
+2°	10818	3005	6.80	84.5	237.2			
	11412	3170	5.75	85.0	210.4			
	12168	3380	4.50	83.5	178.7			
+4°	12168	3380	5.90	85.0	230.2			
	12870	3575	4.80	83.5	201.6			
	13835	3843	3.50	82.0	160.9			

900ZQB-100D

Blade angle	Flow Q		Head H	Speed n	Eff. η	Power (kW)		Impeller Dia. mm
	m ³ /h	L/s	m	r/min				
-6°	5868	1630	5.00	490	80.0	99.9	132	850
	6894	1915	3.50		82.5	79.7		
	7596	2110	2.25		79.0	59.0		
-4°	6660	1850	5.00		80.5	112.7		
	7488	2080	3.75		84.0	91.1		
	8388	2330	2.25		80.0	64.3		
-2°	7578	2105	4.60		83.5	113.8	160	
	8028	2230	3.90		85.0	100.4		
	9072	2520	2.25		80.0	69.5		
0°	7560	2100	5.50		80.5	140.8		
	8658	2405	4.00		85.0	111.0		
	9684	2690	2.50		80.9	81.5		
+2°	8460	2350	5.20	82.0	146.2			
	9378	2605	4.00	85.0	120.3			
	10244	2846	2.80	81.5	95.9			
+4°	9468	2630	4.75	84.0	145.9			
	10080	2800	4.00	85.0	129.3			
	10818	3005	3.00	81.8	108.1			

900ZQB-125

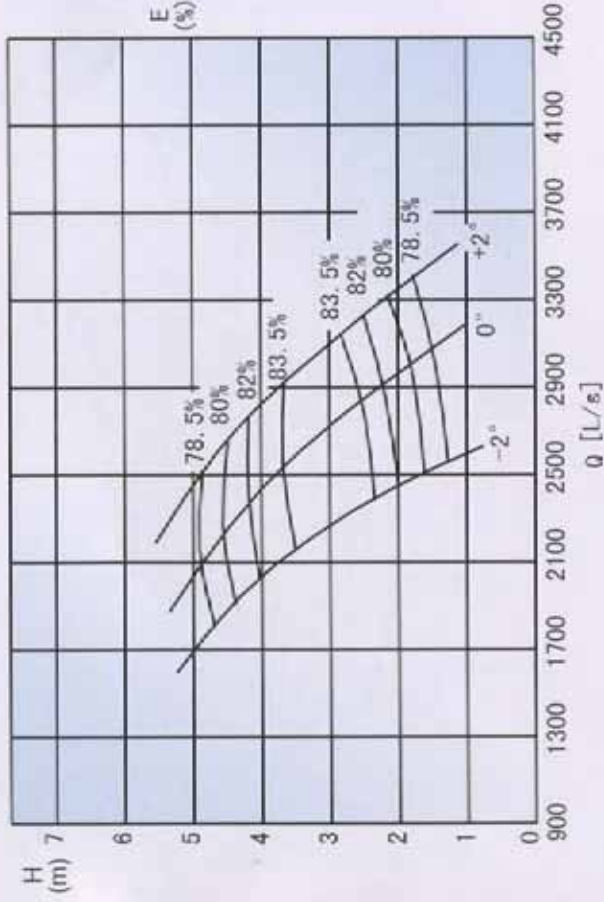

900ZQB-125

Blade angle	Flow Q		Head Speed H n	Eff. η %	Power (kW)		Impeller Dia. mm
	m ³ /h	L/s					
-2°	7056	1960	4.30	80.0	103.3		850
	8136	2260	3.00	83.5	79.7	115	
	8892	2470	1.90	80.0	57.5		
0°	8568	2380	4.20	82.0	119.6	132	850
	9756	2710	3.00	83.5	95.5		
	10620	2950	2.00	80.0	72.3		
+2°	9540	2650	4.50	80.0	146.2		850
	10944	3040	3.20	83.5	114.3	160	
	11700	3250	2.40	80.0	95.6		

900ZQB-160

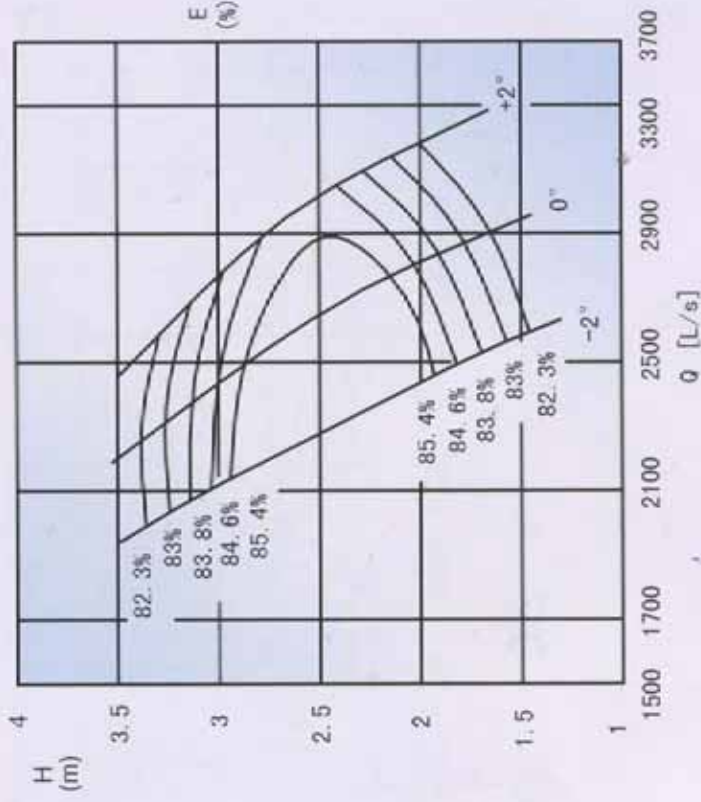

900ZQB-160

Blade angle	Flow Q		Head Speed H n	Eff. η %	Power (kW)		Impeller Dia. mm
	m ³ /h	L/s					
-2°	7315	2032	3.25	82.3	78.7		850
	8492	2359	2.24	85.7	60.5	90	
	9234	2565	1.57	83.0	47.6		
0°	8568	2380	3.12	82.3	88.5	110	850
	9850	2736	2.25	86.5	69.8		
	10476	2910	1.63	83.0	56.1		
+2°	9968	2769	3.00	82.3	99.0		850
	10656	2960	2.64	84.5	90.7	132	
	11462	3184	2.01	83.0	75.6		

900HQB-50D

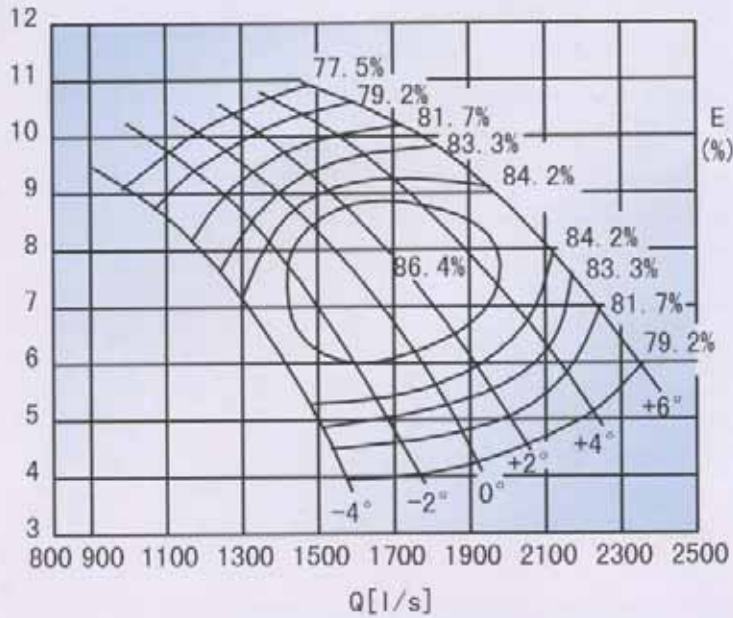

1200HQB-50

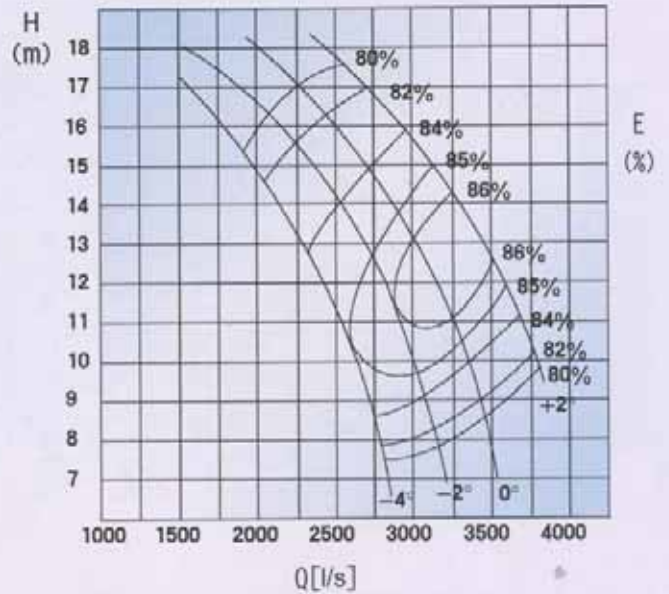

900HQB-50D

Blade angle	Flow Q		Head H m	Speed n r/min	Eff. η%	Power (kW)		Impeller Dia. mm	
	m ³ /h	L/s							
-4°	3790	1053	8.80	490	79.2	114.8	160	755.5	
	5097	1416	6.00		84.2	99.0			
	5587	1552	4.30		81.7	80.1			
-2°	4500	1250	9.00		81.7	135.1			185
	5400	1500	7.00		85.4	120.6			
	6300	1750	4.20		80.4	89.7			
0°	4500	1250	9.80		79.2	151.7	185		
	6016	1671	7.00		85.4	134.4			
	6687	1858	5.00		82.5	110.4			
+2°	4831	1342	10.10		79.4	167.5	250		
	6300	1750	7.50		85.4	150.8			
	7200	2000	5.10		81.7	122.5			
+4°	5587	1552	10.00	81.7	186.3	250			
	6661	1906	8.00	84.2	177.6				
	7756	2154	5.80	81.7	150.0				
+6°	6393	1776	10.00	84.0	207.4	250			
	7200	2000	8.80	84.2	206.1				
	8100	2250	6.90	81.7	186.4				

1200HQB-50

Blade angle	Flow Q		Head H m	Speed n r/min	Eff. η%	Power (kW)		Impeller Dia. mm
	m ³ /h	L/s						
-4°	7236	2010	15	485	81.0	364.9	450	978.6
	8701	2417	12		84.3	337.3		
	9918	2755	9.2		85.2	291.6		
	8305	2307	15.2		81.75	420.5		
-2°	10440	2900	11.3		86.21	372.6	450	
	11318	3144	8.4		81.68	317		
	9720	2700	15		83.7	474.4		
0°	11326	3146	12		86.44	428.2	530	
	12420	3450	9		81.5	373.5		
	10468.8	2908	16.1		83.8	547.7		
+2°	11912.4	3309	14.18		87.22	527.4	600	
	12873.6	3576	12.15		86.9	490		

1200HQB-50A

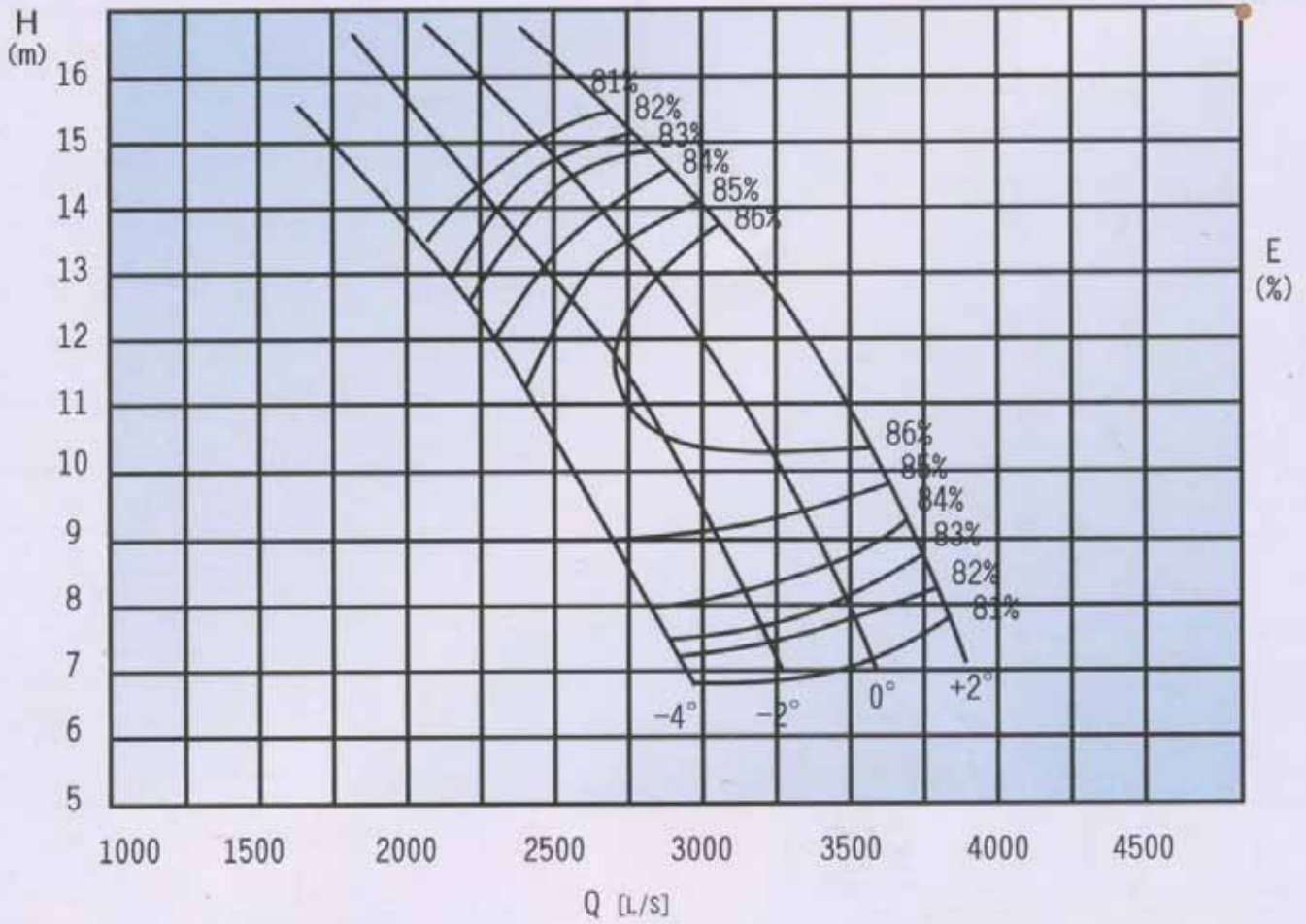

1200HQB-50A

Blade angle	Flow Q		Head H	Speed n	Eff. η %	Power (kW)		Impeller Dia. mm
	m ³ /h	L/s	m	r/min				
-4°	6976	1938	13.40	485	85.4	298.3	350	978.6
	9014	2504	9.80		83.0	290.0		
	10421	2895	6.90		79.8	245.5		
-2°	8160	2252	13.8		85.8	355.3	400	
	10446	2902	9.8		82.2	339.4		
	11668	3241	6.9		81.0	270.8		
0°	9891	2748	13		86.0	407.4	450	
	11668	3241	9.8		81.0	384.7		
	12826	3562.8	6.9		85.2	283.1		
+2°	10557	2933	13.5		86.1	451.1	500	
	12737	3538	9.8		80.0	425.2		
	14020	3894	6.9		85.2	309.4		

1200ZQB-100

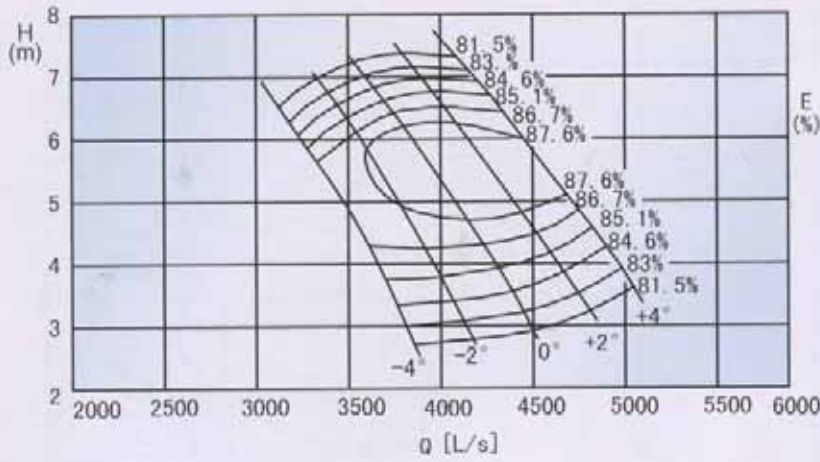

1200ZQB-100*

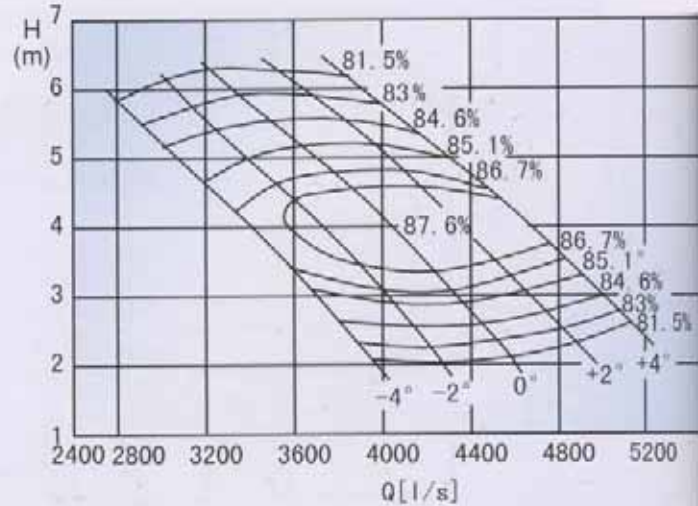

1200ZQB-100

Blade angle	Flow Q		Head H	Speed n	Eff. η%	Power (kW)		Impeller Dia. mm
	m ³ /h	L/s						
-4°	11304	3140	6.43	490	84.7	233.8	280	1000
	13460	3739	5.00		85.4	214.7		
	13644	3790	3.17		81.7	144.3		
-2°	11952	3320	6.84		84.7	263.0		
	13460	3739	5.11		86.2	217.4		
	14904	4140	3.07		81.7	152.6		
0°	13865	3851	6.00		86.1	263.3	315	
	14565	4046	5.11		86.2	235.3		
	16020	4450	3.23		81.7	172.6		
+2°	13824	3840	7.21		84.7	320.7	355	
	15448	4291	5.43		86.2	265.2		
	17028	4730	3.53		81.7	200.5		
+4°	15624	4340	6.45	85.4	321.6			
	16552	4598	5.42	86.2	283.6			
	17964	4990	3.89	81.7	233.1			

1200ZQB-100*

Blade angle	Flow Q		Head H	Speed n	Eff. η%	Power (kW)		Impeller Dia. mm
	m ³ /h	L/s						
-4°	10584	2940	5.40	370	83.0	187.6	250	1100
	12312	3420	4.00		86.9	154.4		
	13752	3820	2.60		84.7	115.0		
-2°	11340	3150	5.70		83.0	212.2		
	14220	3950	4.00		87.6	177.0		
	14940	4150	2.58		84.6	124.2		
0°	11808	3280	6.10		81.5	240.8	280	
	14400	4000	4.15		87.6	185.9		
	16056	4460	2.58		84.6	133.5		
+2°	13176	3660	5.90		82.2	257.7	315	
	15840	4400	3.87		87.6	190.7		
	17100	4750	2.75		84.6	151.5		
+4°	14688	4080	5.60	83.0	269.9			
	16848	4680	4.00	87.6	209.6			
	18000	5000	3.00	84.6	174.0			

1200ZQB-125

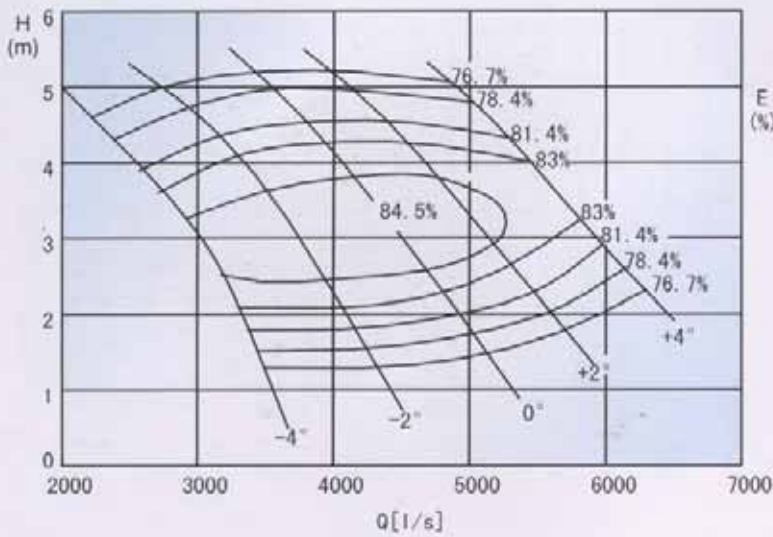

1200ZQB-160

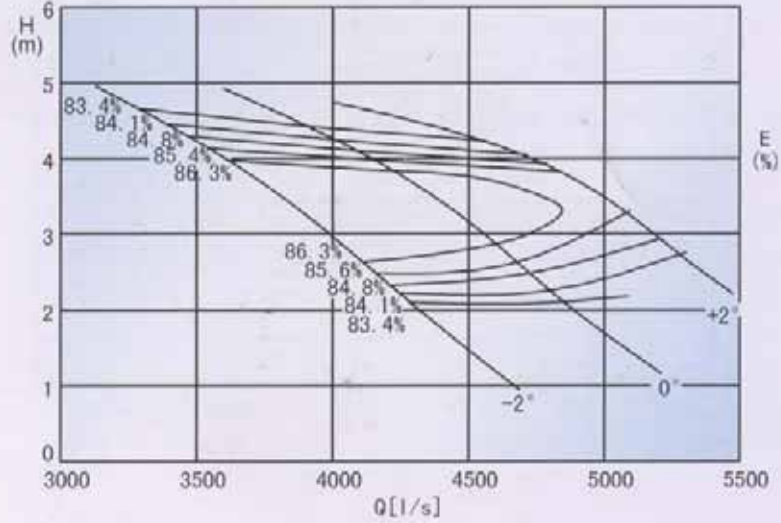

1200ZQB-125

Blade angle	Flow Q		Head H m	Speed n r/min	Eff. η%	Power (kW)		Impeller Dia. mm
	m ³ /h	L/s						
-4°	8820	2450	4.20	370	79.9	126.3	155	1100
	11160	3100	2.80		84.6	100.7		
	12240	3400	1.66		79.9	69.3		
-2°	12240	3400	4.62		79.9	192.9	250	
	13788	3830	2.80		84.6	124.4		
	15300	4250	1.60		79.9	83.5		
0°	13176	3660	4.80		79.9	215.7	250	
	16200	4500	3.00		84.6	156.6		
	18000	5000	1.85		79.9	113.6		
+2°	15228	4230	4.80		79.9	249.3	280	
	18000	5000	3.30		84.6	191.4		
	19800	5500	2.20		79.9	148.6		
+4°	18360	5100	4.66	79.9	291.8	355		
	21096	5860	3.16	83.1	218.7			
	22320	6200	2.48	78.4	192.4			

1200ZQB-160

Blade angle	Flow Q		Head H m	Speed n r/min	Eff. η%	Power (kW)		Impeller Dia. mm
	m ³ /h	L/s						
-2°	12031	3342	4.59	490	83.4	180.4	200	1000
	13968	3880	3.29		86.6	144.6		
	15386	4274	2.11		83.4	106.1		
0°	14440	4011	4.26		84.1	199.3	220	
	16222	4506	3.17		86.6	161.8		
	17323	4812	2.21		83.4	125.1		
+2°	16402	4556	4.21		83.4	225.6	250	
	18112	5031	3.43		85.6	197.8		
	19058	5294	2.63		84.1	162.4		

1400HQB-50

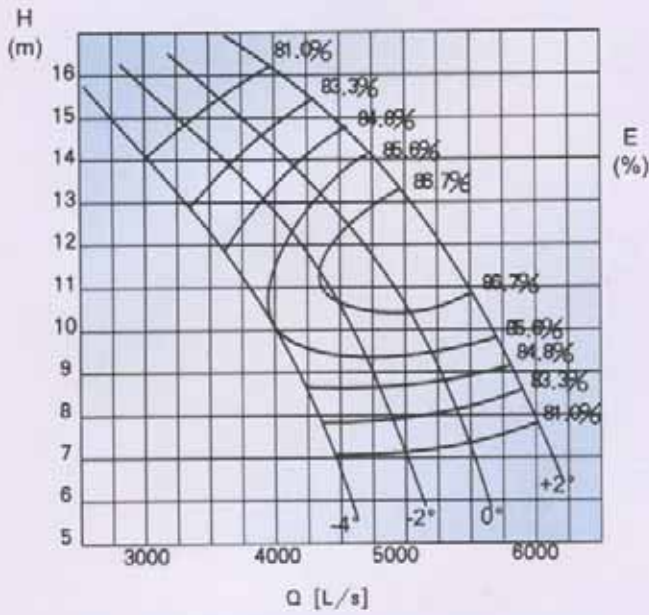

1600HQB-50A

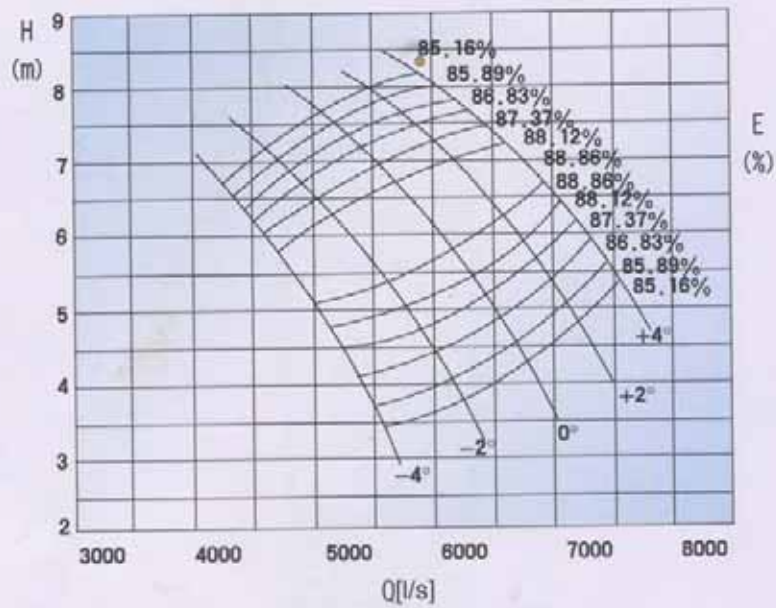

1400HQB-50

Blade angle	Flow Q		Head H	Speed n	Eff. η %	Power (kW)		Impeller Dia. mm
	m ³ /h	L/s	m	r/min				
-4°	10980	3050	14.00	370	81.0	517.1	600	1250
	14400	4000	10.00		85.6	458.4		
	15840	4400	7.20		81.0	383.7		
-2°	12060	3350	14.80		81.0	600.5	670	
	16200	4500	10.80		86.7	549.9		
	17820	4950	7.30		81.0	437.6		
0°	12960	3600	15.40		81.0	671.4	750	
	17280	4800	11.50		86.7	624.6		
	19620	5450	7.40		81.0	488.4		
+2°	14220	3950	16.30		81.0	779.8	850	
	19080	5300	12.00		86.7	719.6		
	21600	6000	7.70		81.0	559.5		

1600HQB-50A

Blade angle	Flow Q		Head H	Speed n	Eff. η %	Power (kW)		Impeller Dia. mm
	m ³ /h	L/s	m	r/min				
-4°	19872	5520	3.71	245	86.1	233.3	480	1480
	18936	5260	4.47		87.2	264.5		
	18036	5010	5.08		88.5	282.1		
	16596	4610	6.04		87.9	310.8		
	15408	4280	6.71		85.3	330.3		
-2°	22104	6140	4.09		85.6	287.8		
	21240	5900	4.73		87.5	312.9		
	20196	5610	5.37		88.8	332.8		
	18108	5030	6.52		87.9	366.0		
	16632	4620	7.18		85.7	379.7		
0°	24048	6680	4.55		86.1	346.3	560	
	23220	6450	5.17		87.3	374.7		
	22248	6180	5.81		88.9	396.2		
	19980	5550	6.96		88.9	426.3		
	18252	5070	7.68		84.5	452.0		
+2°	25560	7100	5.08		85.8	412.4		
	24696	6860	5.67		86.9	439.1		
	23760	6600	6.25		88.9	455.2		
	21708	6030	7.27		88	488.7		
	19728	5480	8.0		84.9	506.6		
+4°	26784	7440	5.57	86.1	472.2	630		
	25884	7190	6.14	87.1	497.2			
	24948	6930	6.65	88.9	508.5			
	23184	6440	7.47	88.1	535.7			
	21168	5880	8.17	85.7	549.9			

1400ZQB-125

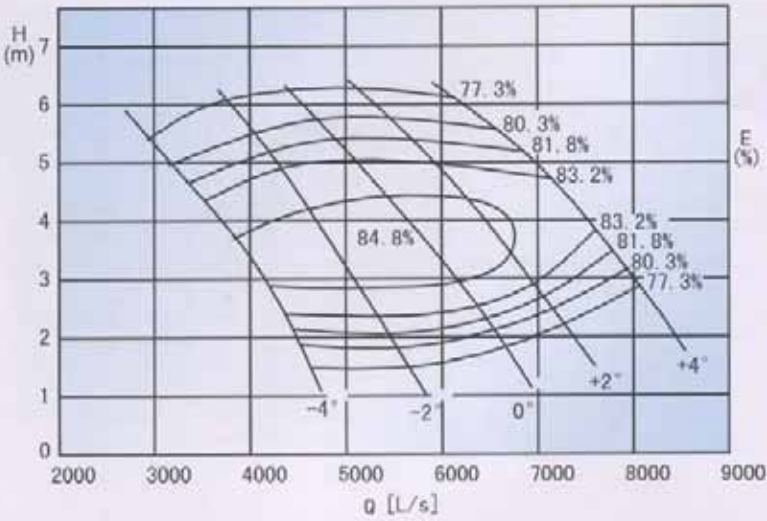

350HQB-50

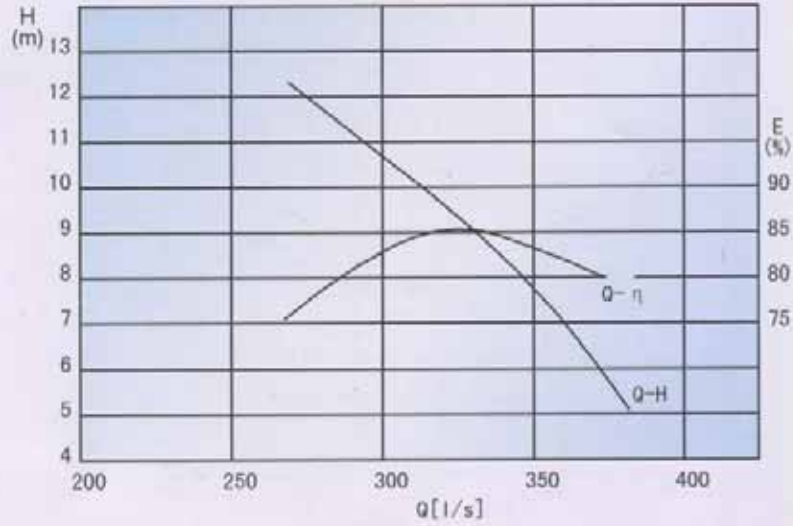

1400ZQB-125

Blade angle	Flow Q		Head H m	Speed n r/min	Eff. η%	Power (kW)		Impeller Dia. mm
	m ³ /h	L/s						
-4°	11448	3180	5.00	370	80.3	194.3	315	1200
	14400	4000	3.40		84.5	157.9		
	16200	4500	1.90		80.3	104.5		
-2°	14400	4000	5.60		80.3	273.7		
	18000	5000	3.20		84.8	185.1		
	19800	5500	1.90		80.3	127.7		
0°	17100	4750	5.70		80.3	330.8	400	
	20520	5700	3.90		84.8	257.2		
	23400	6500	2.20		80.3	174.7		
+2°	19800	5500	5.70		80.3	383.0	500	
	23400	6500	3.90		84.8	293.3		
	25776	7160	2.50		80.3	218.7		
+4°	24732	6870	5.15	81.8	424.3			
	27000	7500	4.05	83.7	356.0			
	28440	7900	3.20	80.3	308.8			

350HQB-50

Blade angle	Flow Q		Head H m	Speed n r/min	Eff. η%	Power (kW)		Impeller Dia. mm
	m ³ /h	L/s						
-4°	9061	293	11.21	1450	80.0	40.0	45	232
	1110	308	10.20		81.0	38.1		
	1143	317.6	9.75		82.0	37.3		

1400ZQB-100

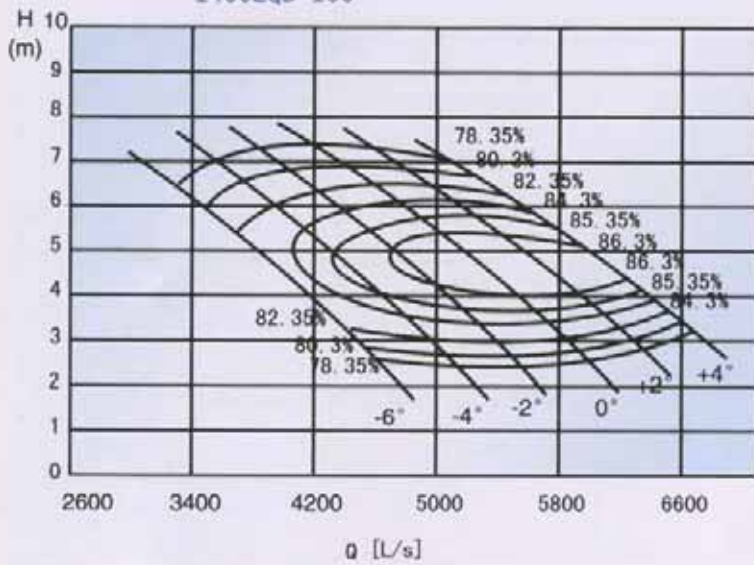

1400ZQB-100*

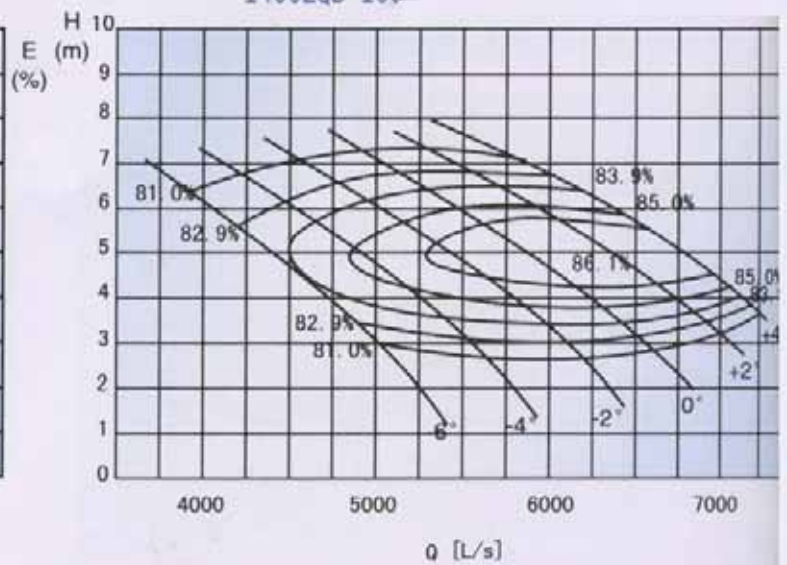

1400ZQB-100

Blade angle	Flow Q		Head H m	Speed n r/min	Eff. η%	Power (kW)		Impeller Dia. mm
	m ³ /h	L/s						
-6°	12630	3510	6.04	370	80.3	259.0	280	1200
	14688	4080	4.20		84.3	199.4		
	16560	4600	2.60		78.3	149.8		
-4°	14976	4160	5.51		84.3	266.7		
	16776	4660	4.04		85.3	216.5		
	18180	5050	2.71		80.3	167.2		
-2°	15300	4250	6.34		82.3	321.2	355	
	17064	4740	5.00		86.3	269.4		
	19800	5500	2.64		80.3	177.4		
0°	17714	4921	5.71		82.3	334.9		
	19440	5400	4.40		86.3	270.1		
	21600	6000	2.50		78.3	187.9		
+2°	17784	4940	6.56	82.3	386.3	400		
	21384	5940	4.07	86.3	274.8			
	22968	6380	2.77	78.3	221.4			
+4°	20340	5650	5.85	84.3	384.6			
	22428	6230	4.41	86.3	312.3			
	24192	6720	3.13	78.3	263.5			

1400ZQB-100*

Blade angle	Flow Q		Head H m	Speed n r/min	Eff. η%	Power (kW)		Impeller Dia. mm
	m ³ /h	L/s						
-6°	14627	4063	5.85	370	82.5	282.6	315	1250
	15889	4414	4.87		84.0	251.0		
	17696	4916	3.23		81.8	190.4		
-4°	15746	4374	6.11		82.5	317.8		
	17496	4860	4.75		85.3	265.5		
	19302	5362	3.23		82.8	205.2		
-2°	17352	4820	6.17		84.0	347.3	400	
	19216	5338	4.91		86.2	298.3		
	21195	5888	3.23		83.2	224.2		
0°	18671	5186	6.46		84.3	389.9		
	20880	5800	5.06		86.3	333.6		
	23031	6397	3.36		83.2	253.5		
+2°	19962	5545	6.59	83.7	428.3	500		
	22257	6183	5.34	86.8	373.1			
	24551	6820	3.07	80.5	255.1			
+4°	21367	5935	6.59	83.0	462.3			
	23748	6597	5.19	86.3	389.2			
	26043	7234	3.66	82.5	314.8			

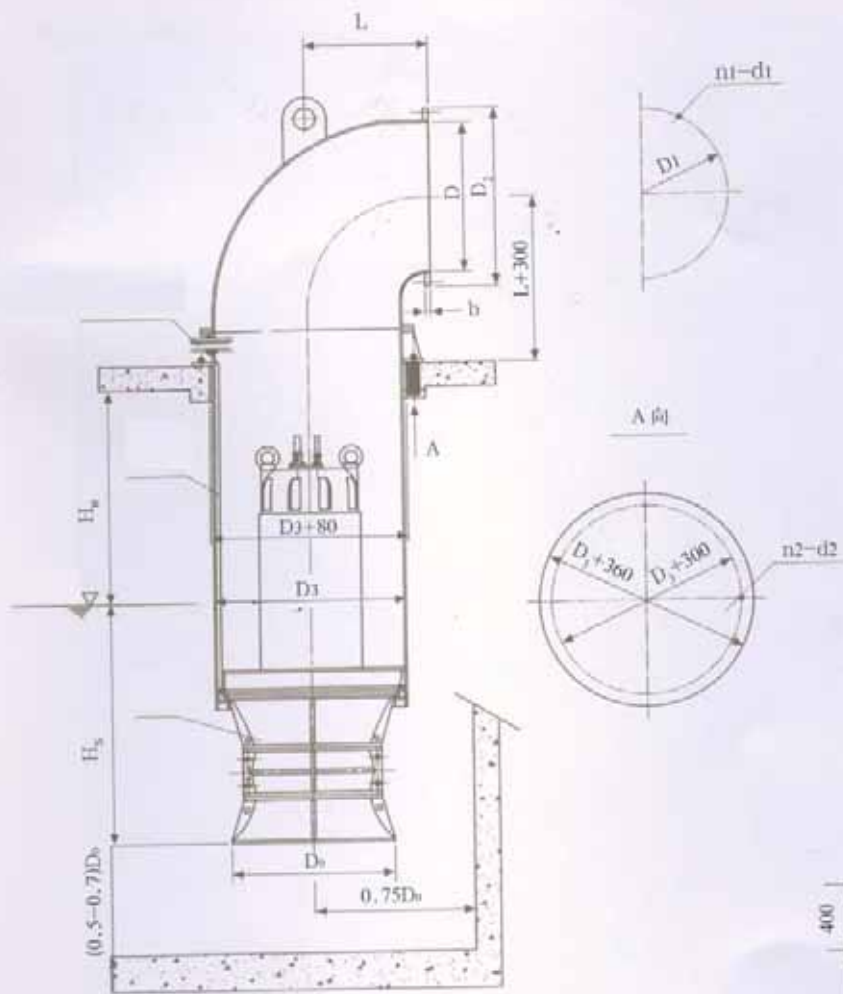

system 3

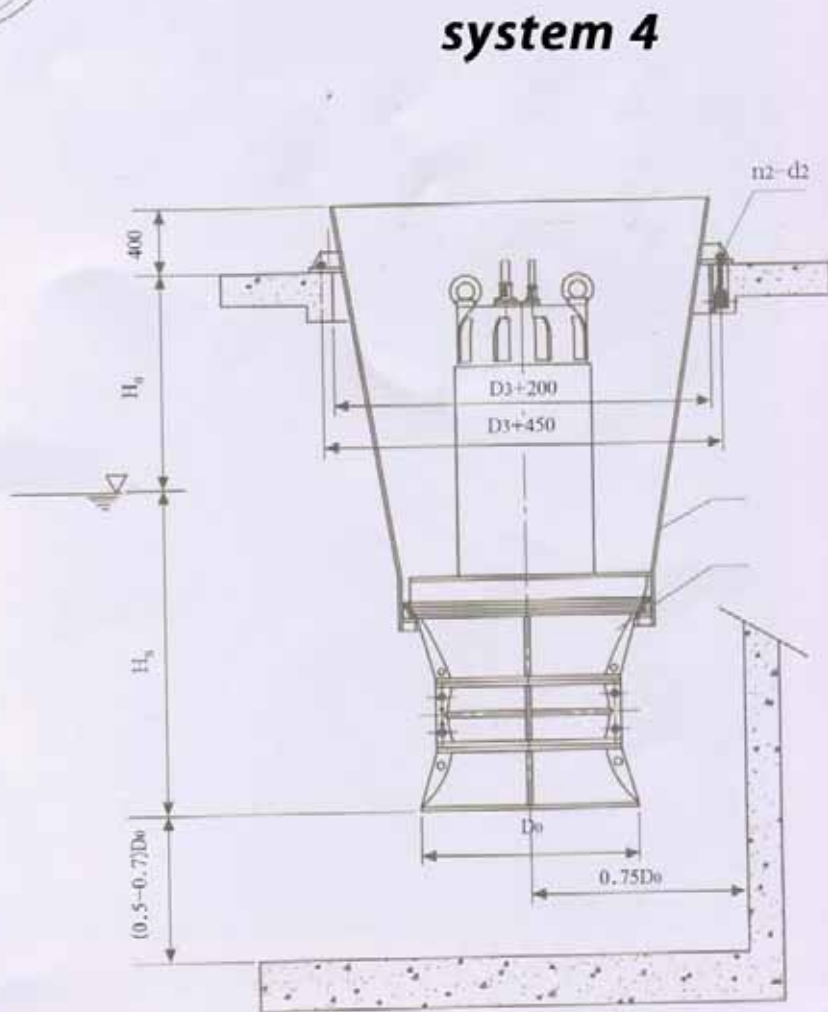

system 4

Dimensions

system 1

Sr. N.	Type	H ₅	H ₆	D ₀	D ₃	n ₂ -d ₂	D	D ₁	D ₂	b	m-d ₁	Pump Wt.	Column Wt.	Pump Ht.
												(kg)	(kg/m)	(mm)
1	350ZQB-70	800		500	600	6-Φ22	400	495	540	20	8-Φ22	500	120	1730
2	350ZQB-70D													
3	350ZQB-100													
4	350ZQB-125													
5	350HQB-50	600			650							640		
6	500ZQB-50	1000		700	800	8-Φ26	600	705	755	20	12-Φ22	1100	160	2000
7	500ZQB-50D				1930									
8	500ZQB-70				1740									
9	500ZQB-70D				2010									
10	500ZQB-100				1740									
11	500ZQB-125				1740									
12	500ZQB-160				2090									
13	600ZQB-100				2090									
14	600ZQB-160				2220									
15	500HQB-50													
16	500HQB-50A	900		830	1000	8-Φ26						1800	200	2600
17	600HQB-50													2650
18	600HQB-50A													2900
19	700HQB-50	1000	1700	920	1100	8-Φ26	800	920	980	25	12-Φ26	2500	220	2500
20	700ZQB-50													
21	700ZQB-50D													
22	700ZQB-70													
23	700ZQB-70D													
24	700ZQB-70*													
25	700ZQB-100													
26	700ZQB-100D													
27	700ZQB-125													
28	700ZQB-160													
29	900ZQB-50	1250		1200	1380	8-Φ30	1200	1320	1380	32	12-Φ30	4500	340	3300
30	900ZQB-70													3190
31	900ZQB-70*													3240
32	900ZQB-100D													
33	900ZQB-100	2300	1000											
34	900ZQB-125	1250												
35	900ZQB-160													
36	900HQB-50													
37	900HQB-50D		2500	1400	1600	8-Φ40	1400	1520	1575			6000	480	3740
38	1200ZQB-100													
39	1200ZQB-160													
40	1200HQB-50	2200		1470	1750							10000	610	4670
41	1200HQB-50A													

$$P_z = 1000 \cdot H_{\max} \cdot \pi D_3^2 / 4$$

Dimensions

system 2

Sr. N.	Type	Hs	Ho	Do	D3	D	Dr	D2	b	n1-d1	Pump Wt.	Column Wt.	Pump Ht.											
											(kg)	(kg/m)	(mm)											
1	350ZQB-70	800		500	600	400	495	540	20	8-Φ22	500	120	1730											
2	350ZQB-70D																							
3	350ZQB-100																							
4	350ZQB-125																							
5	350HQB-50	600			650																			
6	500ZQB-50	1000		700	850	600	705	755	20	12-Φ22	1100	160	2000											
7	500ZQB-50D												2000											
8	500ZQB-70												1930											
9	500ZQB-70D												1740											
10	500ZQB-100												2010											
11	500ZQB-125												1740											
12	500ZQB-160												1740											
13	600ZQB-100												2090											
14	600ZQB-160												2090											
15	500HQB-50													1200	2220									
16	500HQB-50A												900											
17	600HQB-50													830	1000						1800	200	2600	
18	600HQB-50A																							
19	700HQB-50												1000											2650
20	700ZQB-50	1700		920	1100	800	920	980	25	12-Φ26	2500	220	2900											
21	700ZQB-50D																							
22	700ZQB-70																							
23	700ZQB-70D																							
24	700ZQB-70*																							
25	700ZQB-100																							
26	700ZQB-100D																							
27	700ZQB-125																							
28	700ZQB-160																							
29	900ZQB-50	1250		1200	1380	1200	1320	1380	32	12-Φ30	4500	340	3300											
30	900ZQB-70												3190											
31	900ZQB-70*																							
32	900ZQB-100D																							
33	900ZQB-100	2300											3240											
34	900ZQB-125	1250																						
35	900ZQB-160																							
36	900HQB-50	1000												3670										
37	900HQB-50D																							
38	1200ZQB-100	2500		1400	1600	1400	1520	1575			6000	480	3740											
39	1200ZQB-160																				3240			
40	1200HQB-50	2200		1470	1750						10000	610	4670											
41	1200HQB-50A																							

$$P_z = 1000 \cdot H_{\max} \cdot \pi D_3^2 / 4$$

Dimensions

system 3

Sr. N.	Type	Hs	Ho	Do	Ds	n2-cl2	D	D1	D2	b	n1-di	L	Pump Wt.	Column Wt.	Pump Ht.	
													(kg)	(kg/m)	(mm)	
1	350ZQB-70	800		500	600	6-Φ22	400	495	540	20	8-Φ22	500	500	120	1730	
2	350ZQB-70D															
3	350ZQB-100															
4	350ZQB-125															
5	350HQB-50	600			650											
6	500ZQB-50	1000		700	850		600	705	755	20	12-Φ22	650	1100	160	2000	
7	500ZQB-50D														2000	
8	500ZQB-70														1930	
9	500ZQB-70D														1740	
10	500ZQB-100														2010	
11	500ZQB-125														1740	
12	500ZQB-160														1740	
13	600ZQB-100														2090	
14	600ZQB-160														2090	
15	500HQB-50														900	
16	500HQB-50A															
17	600HQB-50		830	1000	8-Φ26						700	1800	200			2600
18	600HQB-50A	1000														2650
19	700HQB-50															
20	700ZQB-50	1700		920	1100		800	920	980	25	12-Φ26	736	2500	220	2900	
21	700ZQB-50D															
22	700ZQB-70															
23	700ZQB-70D															
24	700ZQB-70+															
25	700ZQB-100															
26	700ZQB-100D															
27	700ZQB-125															
28	700ZQB-160															
29	900ZQB-50	1250		1200	1380	8-Φ30	1200	1320	1380			900	4500	340	3300	
30	900ZQB-70														3190	
31	900ZQB-70+															
32	900ZQB-100D															
33	900ZQB-100	2300														3240
34	900ZQB-125	1250											5100			
35	900ZQB-160															
36	900HQB-50	1000														3670
37	900HQB-50D															
38	1200ZQB-100	2500		1400	1600							1120	6000	480		3740
39	1200ZQB-160						8-Φ40	1400	1520	1575						
40	1200HQB-50	2200											10000	610		
41	1200HQB-50A			1470	1750											

$$P_z = 1000 \cdot H_{\text{max}} \cdot \pi D_3^2 / 4$$

Dimensions

system 4

Sr. N.	Type	Hs	Ho	Do	D3	n2-d2	Pump Wt.	Column Wt.	Pump Ht.																																																				
							(kg)	(kg/m)	(mm)																																																				
1	350ZQB-70	800		500	600	6-Φ22	500	120	1730																																																				
2	350ZQB-70D																																																												
3	350ZQB-100																																																												
4	350ZQB-125																																																												
5	350HQB-50	600		650	640	1100	160	2000																																																					
6	500ZQB-50	1000		700	850			8-Φ26	1800	200	2000																																																		
7	500ZQB-50D										1930																																																		
8	500ZQB-70										1740																																																		
9	500ZQB-70D										2010																																																		
10	500ZQB-100										1740																																																		
11	500ZQB-125										1740																																																		
12	500ZQB-160										2090																																																		
13	600ZQB-100										2090																																																		
14	600ZQB-160										2220																																																		
15	500HQB-50										900	830	1000	2500	220	2500	2600																																												
16	500HQB-50A																1000	920	1100	2500	220	2650																																							
17	600HQB-50																					1700	920	1100	2500	220	2900																																		
18	600HQB-50A										1250	1200	1380	8-Φ30	340	3240																																													
19	700HQB-50	1000		900ZQB-50	900ZQB-70	900ZQB-70*	900ZQB-100D	3300																																																					
20	700ZQB-50								1250	900ZQB-100							900ZQB-125	900ZQB-160	900HQB-50	3190																																									
21	700ZQB-50D																				1000						900HQB-50D	1200ZQB-100	1200ZQB-160	2500	480																														
22	700ZQB-70																															2200	1200HQB-50	1200HQB-50A	1400	1600	8-Φ40																								
23	700ZQB-70D																																					2500	1470	1750	10000	610	4670																		
24	700ZQB-70*																																											1250	1400	1600	6000	480	3240												
25	700ZQB-100																																																	1000	1470	1750	10000	610	4670						
26	700ZQB-100D																																																							2500	1400	1600	6000	480	3240
27	700ZQB-125																																																												
28	700ZQB-160	1000		1400	1600	6000	480	3240																																																					
29	900ZQB-50								2500	1400	1600	6000	480	3240																																															
30	900ZQB-70	2200		1470	1750	10000	610	4670																																																					
31	900ZQB-70*								1000	1400	1600	6000	480	3240																																															
32	900ZQB-100D	2500		1400	1600	6000	480	3240																																																					
33	900ZQB-100								2200	1470	1750	10000	610	4670																																															
34	900ZQB-125	1000		1400	1600	6000	480	3240																																																					
35	900ZQB-160								2500	1400	1600	6000	480	3240																																															
36	900HQB-50	2200		1470	1750	10000	610	4670																																																					
37	900HQB-50D								1000	1400	1600	6000	480	3240																																															
38	1200ZQB-100	2500		1400	1600	6000	480	3240																																																					
39	1200ZQB-160								2200	1470	1750	10000	610	4670																																															
40	1200HQB-50	1000		1400	1600	6000	480	3240																																																					
41	1200HQB-50A								2500	1400	1600	6000	480	3240																																															

$$P_z = 1000 \cdot H_{\max} \cdot \pi D_3^2 / 4$$

Concrete Installation

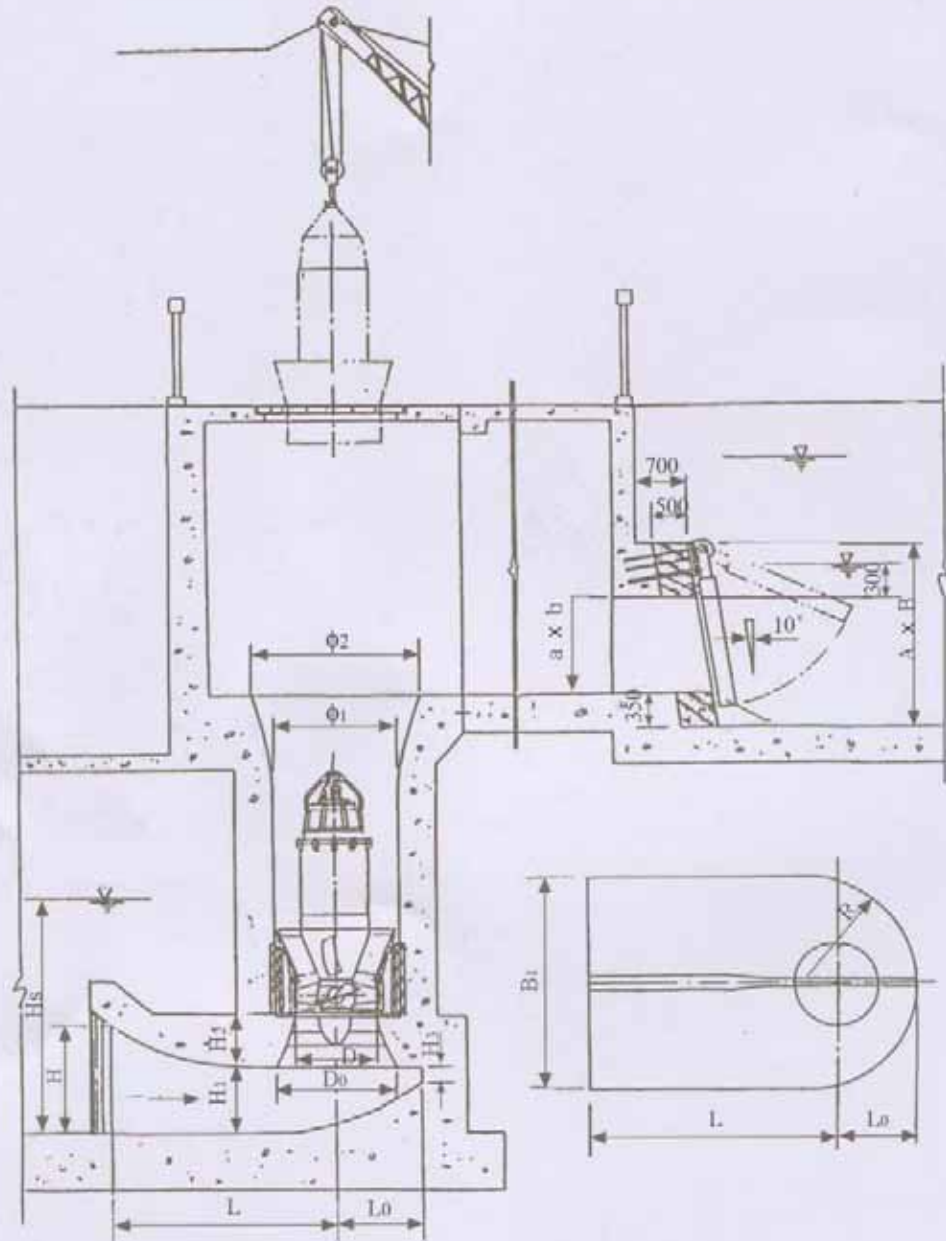

Sr. N.	Type	$\phi 1$	$\phi 2$	D	D_0	H_s	H	H_1	H_2	H_3	L	L_0	B_1	R	$a \times b$	$A \times B$	weight (kg)
1	1200ZQB-100*	1650	2250	1050	1620	3200	1750	880	780	180	3300	1100	2940	1490	1400 × 1400	2600 × 2400	7500
2	1200ZQB-125																
3	1400ZQB-100	1800	2600	1170	1750	3360	1890	950	840	200	3570	1210	3180	1610	1600 × 1600	2800 × 2600	8600
4	1400ZQB-125																

Intake size

B/D	2.0 - 2.5	2 - 3	2.6 - 2.8	2.0 - 2.5	
Z/D	0.5 - 0.75	0.5 - 0.75	0.52 - 0.59	0.5 - 0.7	
X/D	0.8 - 1.0	0.75	1.2 - 1.4	0.5 - 0.75	
L/D		4.0		5 - 8	

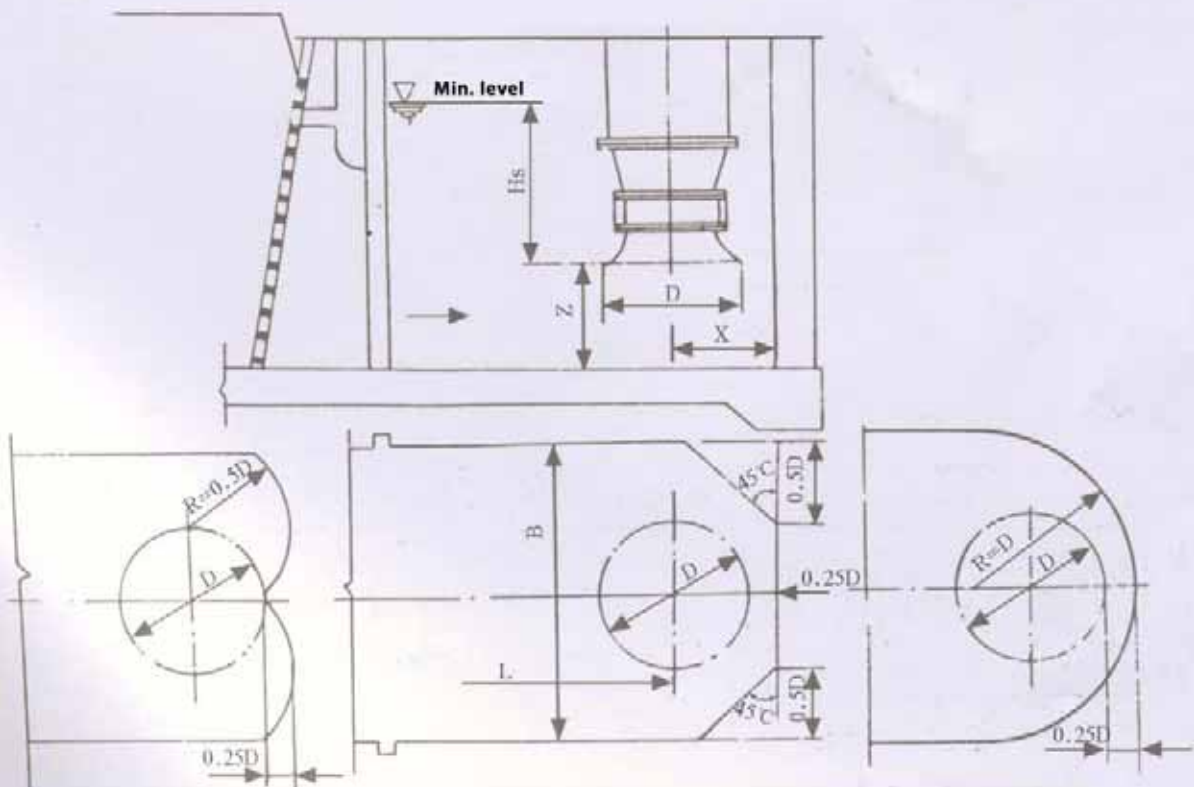

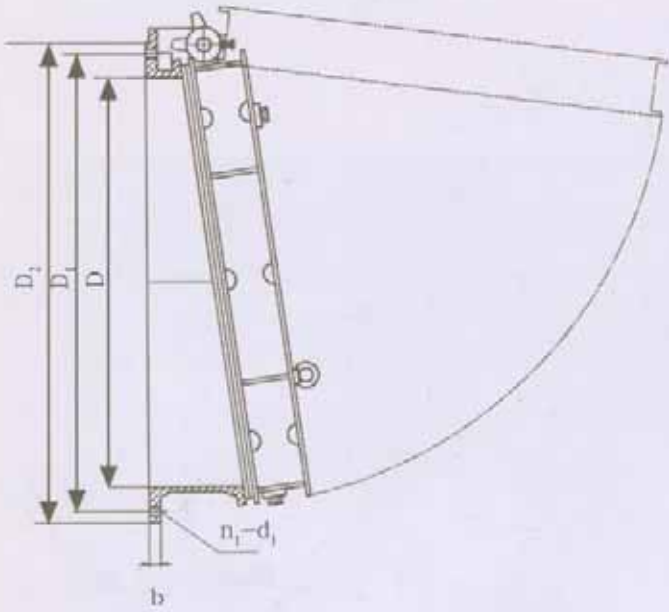

	(mm)				
	D	D ₁	D ₂	b	n ₁ -d ₁
350	350	445	495	20	8-φ22
400	400	495	540	20	8-φ22
500	500	600	640	20	12-φ22
600	600	705	755	20	12-φ27
700	700	810	860	20	12-φ27
800	800	920	980	25	12-φ27
900	900	1020	1075	25	12-φ27
1000	1000	1120	1175	25	12-φ27
1200	1200	1320	1380	25	12-φ30
1400	1400	1520	1575	32	12-φ30
1600	1600	1760	1830	32	12-φ36

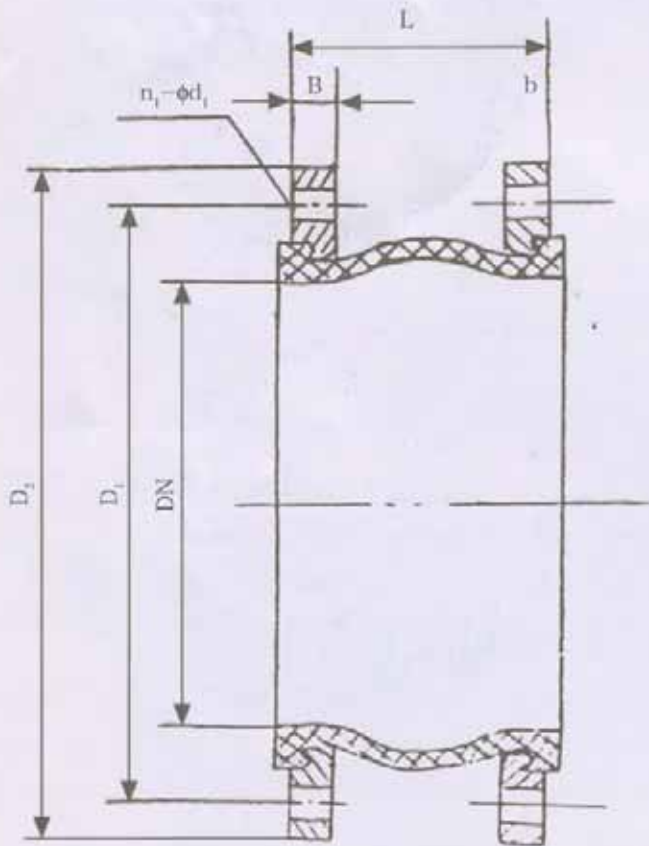

DN	(mm)				
	D ₁	D ₂	n - φd	B	L
350	460	500	16-φ22	38	265
400	515	565	16-φ26	40	265
500	620	670	20-φ26	42	265
600	725	780	20-φ30	42	260
700	840	895	24-φ30	42	260
800	950	1025	24-φ33	42	260
900	1050	1010	28-φ33	44	260
1000	1160	1220	28-φ36	44	260
1200	1380	1450	32-φ39	44	260
1400	1590	1675	36-φ42	44	350
1600	1820	1915	40-φ48	48	350